



The Men's Shed Health & Safety Manual



Please Note

While all care has been taken in the preparation of this material, no responsibility is accepted by the author (s) or AMSA or its staff or its partners for any errors, omissions or inaccuracies.

The material provided in this guide has been prepared to provide general information only. It is not intended to be relied upon or be a substitute for legal or other professional advice. Men's Sheds have an obligation to refer to local, State and Federal legislation and statutory bodies.

No responsibility can be accepted by the author(s) or AMSA or its staff or our partners for any known or unknown consequences that may result from reliance on any information provided in this publication.

Foreword

'Many senior athlete injuries happen when they recognize that some of their physical strength and skills have lost their edge. Fear and pride take over and to avoid others from seeing them struggle, they push themselves to the point of injury'. *Golden Oldies Coach*.

In the Men's Shed environment, we recognise the above Health & Safety trap. Members of the Australian Men's Shed Association have a ***Duty of Care*** to themselves, their Shed colleagues, family members and visitors to operate safely so that afterwards we can return home to our loved ones unharmed. Mates don't like to see each other get hurt.

Responsibility for Shed Safety is everyone's business because safe operating is essential to everything we do. The Committee or authorised persons who establish and oversee Men's Shed operations and the members that supervise activities, have a key role in requiring that safe practices are followed. Members who use the Men's Shed facilities have a corresponding duty to comply with safe practices and adjust any unsafe practices accordingly.

Risk Assessment of the Work Area and the Project

Incidents/accidents can happen if we begin working without properly considering what might go wrong. For example, we might use the wrong tools, take shortcuts that may be dangerous or fail to consider others moving around us. Another example might be the use of a Band Saw on a work-piece that is too small and subsequently may get jammed.

Good Men's Shed Health & Safety practice is to foresee what could go wrong and ensure that all reasonable steps are taken to avoid an incident / accident that might cause injury or damage.

First Aid

All Men's Shed need to have and maintain a First Aid Kit and a Register to record details about all treatments for First Aid and record information about more serious injuries that may need Doctor or Hospital care.

Incident Management

It is important for all concerned that incidents (and near misses) are treated seriously.

- Every incident or near miss signals a flaw in Men's Shed Health & Safety practice and should be reported to the relevant Committee Member at the Men's Shed
- Notes should be made about each incident including the cause
- Corrective action should be taken if reasonably possible to prevent an incident happening again
- If a Member feels it could have Insurance implications or the information might help other Sheds to avoid a similar incident, it should be reported to AMSA on an Incident Form.

Emergency Procedures

Each Men's Shed needs to develop its own **Emergency Plans** to address events such as:

- Serious Injuries (eye damage, amputation, electric shock, burns, heart attack)
- Fires
- Floods
- Burglary / Hold Ups
- Chemical spills

Procedures should be handy and **Signage** should be displayed in the Men's Shed. Details should include

- Local emergency contact numbers for reporting incidents
- Regular 000 call numbers for Police, Fire and Ambulance.

Emergency Exits must be clearly shown and access to them must not be blocked at any time.

Each Men's Shed needs to practice its **Emergency Procedures** at least twice a year and to correct / adjust them where necessary.

Fire & Burglary Protection

Each Men's Shed needs to consider the need for fire protection equipment and the appropriate type of burglary and fire alarms. A Risk Assessment can be undertaken to clear any doubt. AMSA can assist with Risk Assessments if required by contacting us on phone 1300 550 009 or the local Fire Station can also assist.



Chemical Spills

Men's Sheds need to be aware that disposal of waste chemicals can be a little more complex than simply tossing them in the rubbish. Please read and follow any disposal instructions listed on the container.

Common spills might involve the spillage of fuel. Small amounts can be treated locally but if a sizeable amount is lost then it should be reported in the first instance to the Emergency Number 000. Serious spills can be a fire and pollution risk.

Please follow safe handling instructions when handling chemicals.

Men's Health is a corner stone of the Australian Men's Shed Association – therefore sound practice of Men's Shed Health & Safety activities is of fundamental importance. AMSA, our colleagues and families expect us to operate safely and to respect others.

Please implement processes to manage health & safety.

David Helmers
Executive Officer
Australian Men's Shed Association
January 2020

Men's Shed Health & Safety Manual

Foreword

Table of Contents

1. New Member Induction Package
2. Men's Shed Health & Hygiene Policy
3. Health & Hygiene Procedures
4. Men's Shed Risk Management Policy
5. Men's Shed Safety Policy Jan 2020
6. Men's Shed Safety Procedures Jan 2020
7. General Safety Rules
8. Safe Handling of Wood and Wood based products April 2018
9. Food and Kitchen Hygiene Information Sheet January 2020
10. AMSA Policy Statement Working with Children January 2020
11. AMSA Policy Statement Working with People with a Disability December 2019
12. Incident and Near Miss- Recording & Reporting
13. Safe Use of Specific Equipment x power tools
14. Safe Use of Specific Equipment x hand tools
15. Ladder safety campaign brochure
16. Ladder safety campaign poster

Appendices

1. Grievance Policy & Procedures
2. Typical Start Up Equipment and Tooling List
3. Risk Management Assessment worksheets and Support Documents
- 3a. Risk Analysis Thinking Prompts
4. Sample of a Safety Data Sheet (SDS)-All Purpose Detergent Page 1
5. Quarterly Health & Safety Self Audit Checklist
6. Sample Safety Signage for printing and laminating
7. First Aid Register – Sample template

1. NEW MEMBER INDUCTION PACKAGE (6 pages)

i. New Member Application Form

NOTE: Please complete all pages and retain in the Men's Shed files

Name	
Address	
Landline Phone	
Mobile Phone	
Email	
Date of Birth	
Occupation (Past/Present)	
Disabilities: Have you any health conditions or take medication that may affect your capacity to safely operate machinery? Please note: an honest response may not necessarily restrict what you can or cannot do but will improve safety	
Work Skills, Interests & Hobbies	
Emergency Contact Details	
Name	
Phone	
Relationship	

PLEASE COMPLETE FOR APPLICANTS UNDER THE AGE OF 18

Parent / School or Referral Agency _____

Parent / Teacher or Referral Contact Person

Name: _____ Ph _____

Signed Parent/Teacher/Supervisor: _____ Date...../...../.....

Comments / Restrictions

By signing below, I confirm that the above application information about me is true & correct.

Applicants Signature Date...../...../.....

ii. **ASSESSMENT - Member's Work Capacity:**

Member's Name

Assessed knowledge level

- 5 **Green** Is competent to operate all the plant & equipment for a job
- 3 **Blue** Requires supervision to work high risk equipment for a job.
- 1 **Red** Restricted to manual tasks only.

Assessed Physical Ability

(Note if an assessor is in doubt, a member will need to produce a Doctor's clearance before any jobs can be undertaken).

- 5 **Green** Can safely and easily lift and walk with three house bricks
- 3 **Blue** Can safely and easily lift and walk with two house bricks
- 1 **Red** Cannot achieve Blue Level

Assessed Mobility

(Note if an assessor is in doubt, a member will need to produce a Doctor's clearance before any jobs can be undertaken).

- 5 **Green** No movement restrictions evident to work on a job
- 3 **Blue** Some restrictions to mobility that may require job assistance
- 1 **Red** Significant restrictions and cannot achieve Blue Level

Assessed Vision / Hearing ability

(Note if an assessor is in doubt, a member will need to produce a Doctor's clearance before any jobs can be undertaken).

- 5 **Green** Vision and Hearing OK without assistance
- 3 **Blue** Needs glasses or hearing aid to work safely
- 1 **Red** Significant restrictions and cannot achieve Blue Level

Work Capacity Score out of 20 _____

GREEN CARD Requires at least 17 / 20

BLUE CARD Requires at least a 3 (Blue) in each category

RED CARD Could not achieve Blue Level

ASSESSED BY: _____ **DATE** _____

iii. Risk Rating for Men's Shed Machinery

A second aspect of a person's capacity to work safely concerns the machinery used in the various activities.

The following rating scale provides a guide about the risks of machines and equipment and, while not covering all items in Men's Sheds, additional items of equipment can be added to complete the intent of this rating scale.

Note:

It may be that equipment within a Shed may be old or restricted in function in which case the risk rating below may need to be adjusted.

Please adapt the following to suit your own assessment

Please do not overlook the fact that - IF THE TOOL OR MACHINE IS UNSAFE FOR A BUSINESS, IT IS ALSO UNSAFE FOR A MEN'S SHED.

Level 1:

These items are considered to be low risk with little or no training required.

- ✚ Hand tools such as; spanners, hammers, files, vices, manual timber cutting saws, gardening equipment, kitchen equipment including knives
- ✚ Paints and varnishes, general cleaning substances, gardening and kitchen products

Level 2:

These items are considered a medium risk by a person who is familiar with their use and requires only minor supervision. It is likely that Personal Protective Equipment (PPE) is needed and must be used. Safety guards must also be in place prior to use.

- ✚ Metal and Woodworking lathe, pedestal drill press, band saw, circular saw bench, belt sander & disc grinder, electric hand tools, rivet guns
- ✚ Chemicals that contain mild acids or corrosives

Level 3:

These items may require a licence / permit to operate and these need to be sighted by the Committee prior to usage in the shed. This level also applies to contactors who may be working at the shed. At a minimum, moderate supervision is required.

- Fork Lift, Heavy Vehicles, Crane, construction work, plumbing, electrical work, use of welding equipment, oxy-cutting equipment, digging trenches, working in confined spaces.
- Dangerous chemicals should be avoided, however small amounts of fuel may be handled

No explosives are to be handled / stored in Men's Sheds



iv. Men's Shed Membership Name Tag

All members need to wear a name tag when attending the Shed. The main purposes of the name tag are:

- ✚ Security i.e. the tag shows a person is authorised to be in the Men's Shed
- ✚ To indicate the approved rating to undertake work.

The rating is a subjective indication based on two scores for each person:

- ✚ The skills capacity and
- ✚ The complexity of equipment needed.

In most cases, a job will require a mix of skills. It may be that a single person can accomplish the job or he may need some help.

A tag can be seen as the safe work indicator for each member. This may seem like an overkill for a small Shed but its value will be best served in the larger Sheds with a large membership where people may not be familiar with who can do what.

GREEN 1/ 2:

This tag indicates that a person is clear to operate all but the most dangerous equipment/chemicals without much supervision.

For a member holding this tag, he must still ask permission of the Member in charge of operations to use a level 3 piece of equipment or handle such materials. Where relevant, the member must show a current permit/licence to operate specific equipment where it is required.

BLUE 1 OR BLUE 2

Members may have a Blue 1 or a Blue 2 Tag. No blue tagged members will be permitted to operate level 3 equipment – these items are to be operated only by Green approved members.

RED

Members with a Red tag are authorised to work with Level 1 equipment and material only with an appropriate level of supervision.

NOTE:

The above guides need to be used with sound judgement about each case. If doubt exists about a member's abilities, then a separate opinion should be sought prior to making a final decision. Help may come from a source such as a carer or a doctor.



INDUCTION CHECKLIST

Member's Name:	
Start Date:	Tag Rating:
Assessor:	
<p><u>Explain the Shed structure & purpose:</u></p> <ul style="list-style-type: none"> <input type="checkbox"/> Type of work done - How much personal work allowed <input type="checkbox"/> Description of jobs & responsibilities <input type="checkbox"/> Shed Opening Times - Meal times <input type="checkbox"/> Out of hours enquiries <p><u>Explain your policies and procedures on:</u></p> <ul style="list-style-type: none"> <input type="checkbox"/> Drug & alcohol misuse <input type="checkbox"/> Use of telephone <input type="checkbox"/> Non smoking policy <input type="checkbox"/> Members rules of behavior <input type="checkbox"/> Child Protection <p><u>Introduce key people & explain roles:</u></p> <ul style="list-style-type: none"> <input type="checkbox"/> Co-ordinator <input type="checkbox"/> Supervisor <input type="checkbox"/> Other members <p><u>Show the Shed facilities:</u></p> <ul style="list-style-type: none"> <input type="checkbox"/> Car parking <input type="checkbox"/> Eating facilities <input type="checkbox"/> Locker & change rooms <input type="checkbox"/> Wash & toilet facilities <input type="checkbox"/> Work areas, tools, machinery & equipment <p><u>Explain your training:</u></p> <ul style="list-style-type: none"> <input type="checkbox"/> First aid, fire safety & emergency procedures training <input type="checkbox"/> Handling risky substances <input type="checkbox"/> Instruction on safe machine use & special features of each machine 	<p><u>Explain Shed Safety responsibilities:</u></p> <ul style="list-style-type: none"> <input type="checkbox"/> Consultative & communication processes <input type="checkbox"/> Incident reporting procedures, including where to find reporting forms <input type="checkbox"/> Policy and procedures <input type="checkbox"/> Roles and responsibilities <input type="checkbox"/> Reporting risks <input type="checkbox"/> Lock up security for member's belongings & the Shed. <p><u>Show your Shed safety environment:</u></p> <ul style="list-style-type: none"> <input type="checkbox"/> Emergency procedures, exits & fire extinguishers <input type="checkbox"/> First aid facilities <input type="checkbox"/> Information on workplace risks & controls <input type="checkbox"/> Safe use and storage of risky substances <input type="checkbox"/> Safety data sheets (SDS) <input type="checkbox"/> Safe use and storage of Personal Protective Equipment (PPE) <input type="checkbox"/> Location of machine instruction manuals <input type="checkbox"/> Need for safe clothing & footwear <p><u>Member's data records:</u></p> <ul style="list-style-type: none"> <input type="checkbox"/> Privacy of information <input type="checkbox"/> Existing medical problems so that supervisor is aware <input type="checkbox"/> Contact details for emergency use

v. **RECORD OF SAFETY INSTRUCTION** *(amend to suit your Shed's requirements)*

NAME									
	Read Safety Rules			Machine Operation Explained			Assessed OK to Operate		
	Confirmed (Initials)	Date	Instructor (Initials)	Confirmed (Initials)	Date	Instructor (Initials)	Confirmed (Initials)	Date	Instructor (Initials)
General Safety Rules									
Fire Equipment & Drill									
Procedure at Accident									
Paint/Solvent handling									
Tools & Equipment									
Bench Circular Saw									
Slide Compound Saw									
Small Compound Saw									
Band Saw									
Scroll Saw									
Router Bench									
Hand Router									
Biscuit Jointer									
Drill Press									
Electric Hand Drill									
Belt/Disc Sanding									
Hand Belt Sander									
Hand Electric Sander									
Lathe									
Jointer/Planer									
Thicknesser									
Hand Electric Planer									
Bench Grinders									
Hand Electric Grinders									

2. MEN'S SHED HEALTH & HYGIENE POLICY

The basis of the AMSA Men's Shed Policy on Health & Hygiene is a document titled 'National Male Health Policy' published by the Australian Government – Department of Health & Ageing in 2010.

From research, a fundamental benefit of the Men's Shed concept is that time spent in the company of other men provides a positive health outcome. Men's Shed provide a place for men to meet and share in a variety of activities with other men. An activity can be as simple as a friendly chat with other men through to operating machines connected to Men's Shed activities.

Membership is open to anyone who wishes to join – there is a minimal joining fee so that everyone can become fully participating members regardless of their age or background. Members are required to respect other members including those who supervise activities in order that the Men's Shed operates safely.

Members will be asked to provide some personal information when they join. This is to ensure that member's specific health risks are known. This information might prove useful in the event of an emergency. It should be noted that this and other information filed may be used for statistical analysis. When used for analysis, names are not provided so that each member's privacy is protected.

AMSA requires that all Men's Sheds provide sufficient equipment/material to ensure that acceptable hygiene standards are maintained. The activities of the Shed will dictate what is needed.

For example, a Shed that undertakes cooking will need a different hygiene regimen to a Men's Shed that repairs bicycles.

The Committee or authorised person is required to access knowledge about and maintain standards for any activities that require greater than general housekeeping standards.

Members need to be aware of risks associated with skin/eye/mouth/when in contact with chemicals, solvents, paints and other materials used by their Men's Shed.

Members must wear appropriate protection advised by the manufacturer when handling such materials. If in doubt, ask the Member in control of the Shed to provide safety information before using materials. The information should be available either on the product itself or, in a Safety Data Sheet (SDS). <https://diggersaustralia.com.au/safety-data-sheets/>

All machines are to be fitted with guards to prevent injury to operators and people in the vicinity.

Operators are to wear Personal Protection Equipment (PPE) as established by the Shed Committee or authorised person. Operators are also required to check the condition of tools and equipment prior to use and to comply with safety standards and signage.

3. Health & Hygiene Procedures

First Aid

In the event of an injury, the injured person may be in need of First Aid. Sheds are encouraged to have several Members trained in First Aid.

If no-one with training is available, then an Emergency Contact or, in their absence, a Medical Practitioner should be contacted by phone for assistance with treating an injury. The injured member's file needs to be examined because it may contain important information regarding disabilities, medication and allergies that could be critical.

All injuries regardless how slight need to be recorded in the First Aid Register that is to be kept by each Shed. A typical layout is found at Appendix Page 72. This information will help identify trends at a Shed so that problems can be fixed. It is also a legal requirement.

First Aid Kits are required at each Shed. Below is a typical kit however each Shed may have the need for additional items to treat issues that apply to their activity. For example, Sheds that have hot work (cooking and welding) should provide products to treat burns. Each Shed needs to routinely check the kit and where necessary, restock with fresh supplies.

Basic First Aid Kit

QUANTITY	Description
1	Dressing Strips 50's
2	Non-Adherent Dressings 10cm x 10cm
2	Conforming Bandage, 10cm
2	Conforming Bandage, 5cm
3	Wound Dressings, No 15
1	Hypoallergenic Tape
4	Triangular Bandages
2	Eye pads, Sterile
5	Sodium Chloride, 10ml
10	Alcohol Swabs
3	Gauze Swabs, 5's
1	Emergency Foil Blanket
1	Scissors, S/Steel
1	Forceps, S/Steel
12	Safety Pins
2	Latex Gloves
1	Tissues, 10's
3	Plastic Bags
1	Burn cream
1	Notepad
1	Pencil
1	Container
1	1 x 150mm pressure bandage for snakebites.
1	First Aid information book

Hints

- ✚ In a woodwork shop, splinters in the hand are commonplace so ensure there are a variety of tweezers available
- ✚ Extra eyewashes for dust in the eye are very useful
- ✚ Some Sheds have found the 'Spray on' plastic skin to be useful for keeping scratches & grazes clean.
- ✚ Finger bandages with an applicator are also useful as stick-on dressings may come off in the workshop.



Shelf Life Monitoring

Men's Sheds need to identify items that have a defined shelf life and ensure that a diary system is implemented to track and replace items prior to exceeding their shelf life.

Of particular concern are food items. Sheds are required not to take risks with the use of out-of-date food items and instead dispose of them. This also applies to items such as milk stored in the kitchen fridge.

Chemicals/glues/paints/solvents that have shelf lives are also to be treated cautiously. If any of these items are to be disposed of, then it needs to be done correctly.

Please refer to the manufacturer's instructions and/or examine the applicable SDS. If doubt still exists, then contact your local Council for disposal instructions.

An example of a SDS document is shown - Appendices 4



Labelling

Men's Sheds are required to ensure that labels on containers display the contents of the container adequately and accurately.

If smaller amounts are transferred from the main container to a smaller one, great care needs to be taken when using/disposing of the smaller/work containers because harm could result and it is likely that important safety information—imposed by Legislation—will not be completely available on the smaller work container.

For example, a plastic water bottle filled with mineral turpentine would poison and possibly kill a drinker who mistook the contents for water—the water bottle **MUST** be correctly and prominently labelled so that misuse can be avoided.

Buyers of products made by Men's Sheds need to be advised of limitations to usage if harm could result. An example could be the need to refrigerate/store certain food items below 4 deg. C. This should be made clear on the label. Another could be not to exceed certain weights on furniture items such as stools.

These are precautionary measures to guard against the possibility of contravening laws.

Men's Sheds should be aware that each State has its own labeling laws about how labels are to be produced and what information is required.

If Men's Sheds are conducting activities that might require labeling, then it is advisable to seek professional assistance in this regard.

A reasonable approach to determine the minimum needs could be to examine labels for similar products in a retail store and examine the Safety Information that is displayed on the labels.

For more detailed information, AMSA suggests that you visit the Australian Government Department of Environment & Heritage website.

The National Chemical Information Gateway

http://apps5a.ris.environment.gov.au/pubgate/cig_public!/CIGPPUBLIC.pStart

Designed to help you find relevant information about chemicals as quickly and easily as possible, the information has been arranged into topics to help focus your search or you can use the 'search' facility.



Waste Disposal

It is anticipated that most waste from Men's Sheds will utilize the normal services of Local/State Government for disposal.

Items that fall under the heading of 'Trade Waste' comprise all waste that is unacceptable to normal local/State government services. For example, paint tins, pieces of machinery, toxic substances

These items need to be disposed of in an acceptable and legal manner and often the disposal instructions are on the container.

Methods of disposal can vary from place to place so, if in doubt, the Men's Shed should contact the local Council for advice.

No Smoking

AMSA requires that smoking is not permitted at any time in any section of the Men's Shed that breaches State Laws. Smokers are asked to dispose of their cigarette butts safely and without littering the general area of the Men's Shed.



Drugs & Alcohol

AMSA policy is that the illegal use of drugs is not permitted in the Men's Shed at any time and that legal amounts of alcohol is only consumed when no other 'work' activities are taking place that involve the use of power tools or equipment (sensible use of a BBQ is an exception).

The above does not apply to 'Prescription' medication that can be taken in accordance with the doctor's instructions.

Prescription Medication

Members who need to take prescription medication are free to do so at the Men's Shed. However members need to be aware of any medication they are taking which may impact on their ability to work safely with tools and equipment.

This information should be conveyed to the member in charge of operations. If there is any doubt as to the ability of the member to operate tools and equipment then that member should seek written clearance from their GP.

If the medication is possibly required to be administered by another person, the person to provide such assistance needs to be suitably able to do so and be agreeable.

Unless the person providing assistance is qualified, specialized assistance such as administering an injection or changing dressings, should be avoided (unless a critical emergency exists and such assistance is believed essential. The assistance needs to be supervised by a doctor via a phone if the doctor cannot be present.

Report Disabilities (Permanent & Temporary)

Members are required to advise of any existing disabilities when registering as new members. The prime reason is to ensure that the health and safety of the member and others is preserved. The New Membership template (included in the Induction section of this manual) includes a section where members can record any disabilities.

Disabilities may be apparent but it is recognized that some are not and may be the source of embarrassment if made known to other members.

AMSA requires that all disabilities/impairments that can affect safety be made known to the Member in charge of operations or Membership Officer who will note it on file and not communicate it to anyone else (unless the member or carer has made such information common knowledge).

Each member is assigned an 'Operator's Tag' and disabilities will be taken into account in determining the class of Tag awarded. (*refer Risk Management section on Assessment*).

If a current member recovers from a disability or, suffers a disability, it needs to be reported so that the member's record is corrected and accurately reflects the current status prior to undertaking an activity that might compromise health & safety at the Men's Shed.

***Note**

The suggested format at Induction incorporates information normally collected by Men's Shed. It is intended to standardize the format so that this information will be eventually used to become part of the information stored in the computer system 'SMART' aimed at reducing their paperwork and ease administration.

4. What is - Risk Management?

Risk Management is the process used to analyze a situation and then work towards minimizing harm towards people or property. The Risk Management process can be applied to analyzing the downside of any situation – not only Health & Safety.

In its broad sense, the word 'Risk' is the chance that loss or damage from some event will happen. It combines the concept of likelihood and the consequence of the event.

For example, the likelihood of an earthquake happening in Central Australia is unlikely, but if it did happen its consequence could have serious local consequences for Men's Sheds in the district but would not impact on Sheds in coastal areas of the country.

In the area of Men's Shed Health & Safety the risk of injury from using a welding torch is high if the operator is untrained and there could be also be a high risk of fire damage. This risk could be managed by not permitting untrained people to use a welding torch unsupervised and ensuring they wear appropriate Personal Protection Equipment (PPE).

If a risk is considered serious, then it needs to be managed with the aim of minimizing either the likelihood or the consequence of an event happening.

Some risks can be managed using practical measures. For example, the risk of burglary can be managed by locking up portable power tools and other valuables in a tool cage and having a back to base alarm fitted.

It may be difficult to manage the likelihood of a fire happening in a Men's Shed but the consequence can be managed by Emergency Procedures and adequate insurances.

The risk assessment of a Men's Shed would consider many kind of events that could happen and threaten the operation of the Shed, its financial status or the health & safety of people including members, contractors, mentored children / adolescents, and other visitors.

The management aspect deals with actions needed to reduce risk to an acceptable level.

Actions also need to be managed by assigning tasks and resources to fix problem areas.

All Men's Sheds need to regularly assess the risk and ensure action plans are implemented and working properly to reduce risk.

If you need assistance, contact AMSA by email at amsa@mensshed.net



Risk Management Processes for Health & Safety

What Is The Difference Between ‘Hazard’ And ‘Risk’?

Often it is felt that the two terms mean the same thing-it is important for your Shed to differentiate between these terms

A **‘HAZARD’** means a situation or thing that has the potential to harm a person. Hazards may include:

- noisy machinery
- a moving forklift
- chemicals,
- electricity
- repetitive job at your workplace

A **‘RISK’** is the possibility that harm (death, injury or illness) might occur when exposed to a hazard in the Shed.

Examples of what are a hazard and risk

- HAZARD: Frequent bending to load a pallet with boxes
RISK: A manual handling injury to the back
- HAZARD: An extension cord running across a frequently used walkway
RISK: A trip and possible injury resulting.

STEP 1 - Spot the Hazard

The first step is to walk around your Men’s Shed and find the obvious things that could put the health or safety of anyone in danger.

Some of the hazards you will be able to fix straight away by picking up a lead that may cause someone to trip, cleaning up a spill on the floor or moving a frequently used item onto a lower shelf.

There are a number of other ways to find hazards in the Shed, including:

- i. Look at each task members do. Look for any hazards associated with these tasks
- ii. Talk to the members - the people who do the job regularly are the best people to tell you about any hazards associated with their work. Ask members which tasks cause problems or make them concerned. Members may also have had reports from members about particular tasks they’ve had problems with, but not passed on.
- iii. Use safety checklists - checklists are a good way to help you identify some of the common hazards that can be found in the Men’s Shed. Please note that these checklists are generic and should be adapted to suit your own needs.
- iv. Review manufacturers’ information - review the information available from designers or manufacturers, including Safety Data Sheets (SDS) and product labels. Examples of SDS forms are available on the AMSA website
- v. Check injury records and incident reports - by looking at your injury records, you’ll be able to get a good idea of what is causing your members' injuries. You should also check your register of health and safety problems and records of near-misses.

A more systematic approach can be undertaken by using a **Risk Assessment Sheet**.

Under the ‘Spot the risk’ column, write down the name of the task you are reviewing in the ‘Identify the work task or activity’ column. You may even want to break down each of these work tasks into the steps involved in it, from start to end.

If you decide to do this, identify all the steps involved by asking "What happens first?" and then "What do you do next?"

In the "What are the risks associated with each activity" column, write down all the risks you can find.

The **Risk Analysis Thinking Prompts** can help.

STEP 2 - Assess the Risk

When the hazards are identified, the level of risk needs to be established.

We need to identify the likelihood of a risk causing injury, illness or damage to your health.

The list of risks may be surprisingly long, with some posing more safety risks than others.

It is necessary to work out which risks are more serious than others, so that they can be dealt with first. To assess the risk associated with each threat, ask these questions:

1. What is the potential impact of the risk?

- ✚ How severe could an injury or illness be?
- ✚ What is the worst possible damage the risk could cause to someone’s health?
- ✚ Would it require simple first aid only? Or cause permanent ill health or disability? Or could it kill?

2. How likely is the risk to cause someone harm?

- ✚ Could it happen at any time or would it be a rare event?
- ✚ How frequently are workers exposed to the risk?

Answering these questions will help you assess the risk level: whether it is a low risk, moderate risk, significant risk or high risk.

The table below can help with this process.

Potential Impact Of Risk	Likelihood that Risk would cause an Accident				
	Almost Certain	Likely	Moderate	Unlikely	Rare
Insignificant	Significant	Moderate	Low	Low	Low
Minor	Significant	Significant	Moderate	Low	Low
Moderate	High	Significant	Significant	Moderate	Moderate
Major	High	High	High	Significant	Significant
Catastrophic	High	High	High	High	Significant

Identify the Potential impact of Risk

<i>Insignificant</i>	No injuries, low financial loss
<i>Minor</i>	Simple First aid treatment, medium financial loss
<i>Moderate</i>	Significant First aid treatment, high financial loss
<i>Major</i>	Extensive injuries, loss of production capability, major financial loss
<i>Catastrophic</i>	Death, huge financial loss

Assess the Likelihood that the Risk would cause an accident

<i>Almost certain</i>	The event is expected to occur in most circumstances
<i>Likely</i>	The event will probably occur in most circumstances
<i>Moderate</i>	The event should occur at some time
<i>Unlikely</i>	The event could occur at some time
<i>Rare</i>	The event may occur only in exceptional circumstances

Action required to eliminate the Risk

<i>High</i>	High Risk - act immediately to take steps to Fix the Problem
<i>Significant</i>	Significant risk - act immediately to take steps to Fix the Problem
<i>Moderate</i>	Moderate risk - act as soon as practicable
<i>Low</i>	Low risk -manage by routine procedures and reassess within designated timeframe

STEP 3 - Fix the Problem

When a threat is spotted and the risk assessed, ways need to be developed to fix them. This is known as **Risk Control**, and is the third step.

You should always aim to remove a hazard completely from the Men's Shed. Where this isn't practical, you should work through the other alternatives systematically. Working through risks in this way is known as the hierarchy of control. Sometimes more than one control measure should be used to reduce the exposure to risks.



Control Measures

1. Eliminate the risk.

For example, repair damaged equipment; use a lifting machine to do the lifting in the workplace; stop using a dangerous chemical.

If this is not practical, then:

2. Substitute the risk with a safer alternative.

For example, break larger loads down into smaller, lighter loads; use a less toxic chemical.

If this is not practical, then:

3. Isolate the risk.

For example, install barriers to restrict access to risky work areas or machines; use chemicals in a safe dedicated work area.

The size of a Men's Shed is a major consideration for a safe work environment, but it is difficult to find hard and fast rules. The overriding concern is for a safe workplace.

A typical Government workspace is at least 1.8 sq metres, however, to allow for general movement, there must be a minimum of 2.3 sq metres of additional / unused space for each person working in the area. The spare space can include meeting rooms etc. In Men's Sheds it is important for safety reasons not to squeeze too much into a space to comply with safe work regulations.

The foregoing measures may be regarded as minimums but common sense regarding the Men's Shed's activity need to also be a prime factor when arranging the space needs and safe layout for each Shed.

Another good idea inside the work area of the Shed is to paint yellow lines on the floor to mark out where things may or not be stored and where people may or not walk.

If this is not practical, then:

4. Use engineering controls.

For example, place guards on dangerous parts of machinery; use a trolley to move heavy loads; explore use of localized extraction systems.

If this is not practical, then:

5. Use administrative controls.

For example: have clear safety notices on machines; change work practices and organization; rotate jobs to reduce the time spent on any single task; train members in safe work procedures; carry out routine maintenance of equipment

If this is not practical, then:

6. Use personal protective equipment (PPE).

For example, provide workers with PPE such as gloves, masks or ear muffs and train them to use PPE correctly.

Finding safety solutions

There are many ways to find safety solutions.

- At regular toolbox meetings, ask members for their ideas. They may already see safer ways to do things.
- Look at the information available from designers or manufacturers, including Safety Data Sheets (SDS) and product labels.
- Talk to other Men's Sheds. Get help from any associations or groups involved in similar functions. They may have seen the problem before and know how to fix it.
- Consult a professional OHS specialist
- Talk to AMSA.

STEP 4 - Evaluate Results

Risk management is not a one-off event - it is an ongoing process. Once you have identified the threats, assessed their risk and fixed them, you need to follow up with the fourth step of the risk management process 'Evaluate results'.

Evaluation is an important step in the risk management process. After you think that you have fixed the problem, find out whether the changes have been effective.

It is useful to think through the steps again to ensure no new risks have arisen.

Talk to your members. Ask these questions:

- Are the changes making a difference?
- What do your members think?
- Will the solutions reduce risks and prevent injury or illness?
- Do they create new risks or increase the risk of existing ones?
- Any ways to make further improvement?

Set a date to re-evaluate the task, choosing a timeframe appropriate to the task and the risk involved.

5. Men's Shed Safety Policy

The Australian Men's Sheds Association understands that operating in a safe and responsible manner is fundamental to the continued success and growth of the Men's Shed services throughout Australia.

Sound safety practices result in low accident rates and consequently low Insurance premiums. A careless approach to safe work practices may lead to a claim for insurance being denied by the Insurer.

We value our members and place the utmost importance on the safety of all persons working or visiting our Men's Sheds.

We are committed to:

- ✚ Encouraging and supporting a culture whereby all members may identify, report, assess and control safety risks in their Men's Shed
- ✚ Continuously improving our safety to reduce work related injury, illness and harm
- ✚ The provision of induction training and briefings to ensure all members, subcontractors and visitors have the relevant skills and knowledge to understand risks and their safety obligations
- ✚ Compliance with all applicable laws, regulations, statutory obligations and other relevant requirements
- ✚ Ensuring we have the resources and skills necessary to effectively manage our identified safety risks
- ✚ Maintaining and improving a safety management system
- ✚ Consulting and communicating with our members about safety and
- ✚ Providing information and documentation to assist with effective safety management.



6. Men's Shed Safety Procedures

Warning Tags

AMSA recommends that tags are used to issue warnings to potential users **NOT** to use a piece of equipment because it is faulty or is being serviced.

Examples:



Minimum Number Of People In The Shed

AMSA recommends that a minimum of two members be in attendance while the Shed is open. The reason is to ensure that if a member is in need of help, another person is there to provide assistance.

Safety of Visitors

Australian Safety legislation sets out that when visitors come to the Men's Shed, you have a duty of care to ensure they are safe. The visitors also have a corresponding responsibility to follow the safety policy and procedures and to take care not to endanger other people.

In practical terms, AMSA and our Insurers require that all visitors to Men's Sheds be advised about any known dangers / risks they could encounter in the Shed.

For example, it may not be necessary to give an extensive induction if the purpose of the visit is just to drop off some tools. However, on the other hand, if the visitor is a contractor, then he / she requires a more extensive briefing and, in particular, the briefing needs to advise all known risks that apply to the work area and the task.

AMSA recommends that visitors who enter the premises be given a visitors badge that simply says '**VISITOR**'.

As a further measure, AMSA recommends that visitors be accompanied at all times when on the Men's Shed premises. Additionally, the normal safety practices that apply to members also apply to visitors. These include:

- ✚ Wearing shoes that cover the toes
- ✚ Long hair covered by a net if near to machines
- ✚ Wear safety glasses
- ✚ Wear all other appropriate PPE
- ✚ Observe all safety signage

Emergency Procedures

AMSA recommends that all Men’s Shed develop an Emergency Information Poster and affix it prominently to the Noticeboard. At a minimum, the following information needs to be displayed.

	TELEPHONE	ADDRESS
POLICE		
FIRE		
AMBULANCE		
CLOSEST DOCTOR		
CLOSEST HOSPITAL		
POISONS INFORMATION CENTRE		
OTHER EMERGENCIES	<i>SHED AFTER HOURS</i>	<i>N/A</i>
SHED HEALTH & SAFETY OFFICER		<i>N/A</i>

List all people with a First Aid Certificate:

.....

Personal Files:

The Men’s Shed should maintain a member file system recording the member’s medical conditions / medications and an Emergency Contact person. The information should be sought on the membership application form, updated annually or more often if necessary. It is very important that each member check this file before administering any first aid or medication. If in any doubt, contact the injured member’s doctor or emergency contact person.

Evacuation Plans

A person anywhere in the Men’s Shed should be able to respond to an Emergency Alarm by quickly and safely exiting the building and moving to a safe area- the designated Muster Points. For most Men’s Shed, Emergency Exits will be obvious and easily recognised. However, they must be clearly marked and, in the Men’s Shed work area, should have access paths clearly marked (such as painted floor marks). Access to Emergency Exits must always be kept clear. It is recommended by AMSA that a sketch of the Men’s Shed ‘footprint’ be produced showing the location of Emergency Exits, Muster Points and Emergency

Equipment such as:

- ✚ SDS Register
- ✚ First Aid Kit
- ✚ Telephone
- ✚ Fire Extinguishers
- ✚ Fire Hose

Other useful information to have on the sketch includes:

- ✚ Electricity Main Board
- ✚ Water, Gas and Sewer Mains
- ✚ Fuel & Inflammables storage
- ✚ Chemicals storage area

Emergency Assembly (Muster) Point

Each Men's Shed should include, on the sketch, a safe and sufficiently large, nearby place where all Shed members and visitors should move to in the event of an Emergency that requires an Evacuation.

Following an Evacuation, a person in charge of operations will ensure that all people are accounted for and notify the attending authorities accordingly. The member in charge of operations will be the sole spokesperson.

Media Handling

If any TV, Radio or print media seeks information about the Emergency, the Shed members should not give interviews and instead refer them to a Committee member with delegated authority to speak on behalf of the Men's Shed.

Note: Auspiced Sheds may have other arrangements for dealing with media. The auspiced shed requirements will take precedence in this case.

Safe Use of Chemicals

- AMSA strongly recommends that Men's Shed avoid or minimise the exposure / use of harmful chemicals if possible. Chemicals that are stored at the Men's Shed need to be done in accordance with the supplier's instructions that are set out in a Safety Data Sheet (SDS).
- Australia introduced the GHS (Globally Harmonized System) in 2012 and as of the 1st of June 2015 all Material Safety Data Sheets (MSDS) had to be replaced with Safety Data Sheets (SDS-almost exactly the same with a name change to comply with the global standard which is managed by the United Nations. A significant difference with the SDS is that it must be revised every 5 years.
- A SDS needs to be on-site for each chemical and members that use it need to be made aware of the SDS and be required to read it prior to usage.
- Of particular importance is the safe use of the chemical, its storage and disposal of waste. All members, who use the chemical, need to follow the applicable instructions.
- All chemicals, where possible, need to have the packaging / labelling prominently displayed on the container to ensure that the chance of confusion about the contents is minimised.
- If a member has any doubts about a chemical, how to use it safely, store it or dispose of it, he need to access the SDS file to find the answer – if necessary, he should also ask another member if still unsure.
- AMSA recommends that all sheds obtain and file an SDS for all chemicals and dangerous goods that are stored in /used by the Shed.
- For more detailed information, AMSA suggests that you visit the Australian Government Department of Environment & Heritage website:

http://apps5a.ris.environment.gov.au/pubgate/cig_public!/CIGPPUBLIC.pStart

Designed to help you find relevant information about chemicals as quickly and easily as possible, the information has been arranged into topics to help focus your search or you can use the 'search' facility



Electrical Safety / Tagging

Purpose: to ensure that all members are aware of the general guide for electrical safety.

Procedure Details

1.1 Installations

All electrical work must be done by properly licensed people. All electrical work undertaken on-site is required to be carried out in compliance with the relevant statutory Acts and regulations.

1.2 Portable Electrical Equipment

All portable electrical power tools used on site should be protected at all times by an approved earth leakage protection device.

All general purpose outlets (supply points) including outlets fitted to, or supplied from, portable or mobile generating equipment should be protected by an earth leakage protection device.

Members in charge of operations should ensure that all electrically powered tools, lamps, extension leads, transformers and other such equipment are:

- ❖ Readily identifiable
- ❖ Inspected prior to use
- ❖ Inspected, tested and tagged in accordance with the Code of Practice by a competent person at least every twelve (12) months.

Any powered item which has fallen into water or any other liquid should not be touched prior to it being safely isolated. The equipment should then be dried, tested and inspected before re-use.

Under no condition should anyone but a qualified electrician make repairs or modifications to any electrical equipment.

1.3 Defective Equipment

The Member in charge of operations has the authority to remove defective or dangerous equipment from use in the Men's Shed immediately without warning or notification. This applies to major defects and minor defects (e.g. poorly wired plugs and sockets with sheathing exposing internal wires). All defective equipment will be tagged 'Out of Service'

1.4 Extension Leads, Flexible Cords and Cables

Electrical extension leads, flexible cables and cords should be protected from damage at all times. Inside the Men's Shed, leads that are intended to be in place for an extended period of time should be secured at a height not less than 2.4 metres instead of cluttering the floor and posing a dangerous tripping and electrocution hazard.

Safe Use Of Ladders

The following precautions are to be implemented:

Setting Up

- ✚ Before use inspect the ladder for damage including ropes, pulleys and locking gear and DO NOT use if damaged
- ✚ Always place a ladder at a slope of 4 to 1 (75 degrees to the horizontal) and fix securely at top and bottom to prevent displacement/movement
- ✚ If used to access a work space or platform, the top of the ladder must extend one (1) metre above the platform or into the space
- ✚ Ladders MUST NOT be placed at a doorway unless the door is locked or guarded
- ✚ Ladders MUST NOT be placed against windows, electrical conductors or bus bars
- ✚ Ladders MUST NOT be set up on scaffolding or elevated work platforms to gain extra height.

Climbing

- ✚ Use both hands to ascend or descend
- ✚ Only one person is allowed on a ladder or steps at any one time
- ✚ DO NOT climb higher than the third rung from the top
- ✚ A second person needs to be on hand to steady the ladder or steps. AMSA recommends this person also wear a hard hat for protection against falling objects.
- ✚ All tools and materials which cannot be safely secured to the person's belt must be independently transferred or hoisted to the work location.

Working On

- ✚ All work is to be performed whilst facing the ladder
- ✚ Over reaching is NOT PERMITTED
- ✚ The use of power tools on ladders is restricted to those tools which can be easily operated with one hand
- ✚ After use, store ladders in a dry, well ventilated space, protected from the weather and provide adequate horizontal support to prevent sagging.







7. General Safety Rules

Only members who have been assessed & approved are permitted to use the power tools & equipment

1. Do not operate machines whilst under the influence of drugs, alcohol or medication
2. Wear approved eye & ear protection & when necessary hair covers & dust mask
3. Do not wear ties, loose gloves or loose clothing
4. Never start a machine before clearing away nearby objects
5. Always use the guards & ensure they are correctly spaced from the cutter
6. Ensure there is enough space on the feed & exit sides for the work piece
7. Where applicable ensure the Dust Extraction is "On" & functioning
8. Before starting warn anyone using tools to prevent reaction to sudden noise
9. When switching "On" keep well clear of cutters
10. Let the machine get to full speed before contacting the work piece
11. Turn the machine "Off" when a job is jammed.
12. When finished turn machine "Off". Wait for cutter/blade to stop before removing work piece.
13. Always turn "Off" at the machine NOT the wall switch to prevent unexpected starts if someone else inadvertently operates the wall switch.
14. Clean up to keep the area safe

If a machine does not seem to be functioning correctly:

-  **STOP**
-  Unplug the machine from power
-  Put a 'Warning' notice on the machine
-  Notify a Supervisor



8. Safe Handling and Processing of Wood and Wood Based Products

i. Storage and Protection

- Storage areas for particleboard, hardboard, plywood and medium density fibreboard (MDF) should be dry and well ventilated.
- Changes in panel moisture content will cause bowing and this may cause the panel to pinch the saw blade during cutting.
- Sawn timber which has been dried should be handled similarly to panel products
- Unseasoned timber, when not immediately used, should be block stacked on level ground or suitable bearers.

ii. Manual Handling

- Safe handling practices based on manufacturer's specifications are recommended.' For lifting, lowering or carrying loads the following guidelines are appropriate:
- In seated work, it is not advisable to lift loads in excess of 4.5kg
- The risk of back injury increases with objects above 16-20kg, therefore from the standing position, it is advisable to keep the load below this range
- Mechanical lifting and/or team lifting should be used to reduce the risk of injury with heavier lifts
- Generally, no person should be required to lift, lower or carry loads above 55kg unless mechanical assistance or team lifting are provided.



iii. Formaldehyde

Wood panels such as particleboard, medium density fibreboard and plywood, laminated veneer timber and laminated beams which utilise formaldehyde-based adhesives may emit very small amounts of formaldehyde into the air.

To reduce this amount even further it is recommended that the product is stored in a well ventilated space.

iv. Machinery Safety

The basic principles of machinery safety are:

- Identification of all hazards
- Assessment of risk associated with a hazard
- Elimination or reduction of risk
- Use of guards and other safety devices
- Use of safe work practices



Woodworking machinery needs to be adequately safeguarded against injuries caused by cutting tools.

During operation, access to cutters must be restricted by guards to prevent hands, other parts of the body and clothing coming into contact with them.

Emergency stop buttons should be strategically located and clearly visible.

v. Noise

Even if noise levels are below that which may damage hearing, it can contribute to other dangers by masking warning signals and hindering communication. Whenever possible, noise levels should be reduced by engineering controls.

Any person working in a high noise area should wear personal hearing protection.

vi. Wood Dust Control

Wood dust produced by machining or sanding may be irritating to the eyes, respiratory system and the skin. Prolonged exposure to wood dust may cause nasal and nasal cavity cancer by inhalation.

Particular care should be taken when machining preservative treated wood, due to the possible health effects from the added chemicals. The best way to control dust inhalation is by the use of a properly designed and maintained dust extraction system, work areas should also be well ventilated.

In the absence of a dust extraction system, an approved dust mask should be used, and eye protection worn.

The wood dust produced when machining MDF and hardboard is finer and more readily dispersed into the air than most solid wood, plywood or particleboard. This dust requires a higher level of extraction efficiency.

For wood dust from pine timber particleboard, dust extraction systems require a minimum capture velocity of 10 to 20 m/sec, compared with 20 to 30 m/sec for wood dust from MDF, hardboard and some hardwoods.

The higher capture velocity required for these finer wood dusts can often be met by simple modifications to existing equipment. Reducing the size of the collector hood openings and placing them as close as practicable to the point of dust collection will assist in raising capture velocities.

Collection efficiency will also be improved by closing off ducts connected to machines which are not in use subject to maintaining the recommended minimum air velocity in the remaining ducting.

For fine wood dusts, such as that from MDF, the air velocity in the ducting needs to be 15 to 20 m/sec to prevent an accumulation of dust.

High concentration of wood dust, particularly from sanding, can form explosive mixtures with air. It is recommended that ducting should be fitted with explosive vents.

Wood dust which gathers on the floor, ledges, machinery pits etc, should be removed by vacuum or wet sweeping. Use of compressed air should be avoided. If it is used, the user should wear a suitable dust mask or respirator.

vii. Protective Clothing

In addition to dust masks, eye and hearing protection there is also clothing, some woods and wood dusts can contain naturally occurring chemicals which may cause dermatitis and asthma in some people. At all times it is recommended to use long sleeve shirts and gloves to avoid skin contact.



viii. Wood Finishes

Many of the finishes applied to wood and wood products, such as paints, lacquers and varnishes, contain solvents and other chemicals which may have possible health effects. It is important that all materials be checked for to ensure their safe use.

A Safety Data Sheet (SDS) should be obtained from the manufacturer, and labels on the container should be examined for information about possible health effects and how to avoid them.



ix. Disposal of Wood

Most wood can be disposed of at landfill sites or by incineration, although increasing emphasis is being placed on recycling materials. The exception can be wood that has been treated with chemicals.

Before disposal of treated wood, reference should be made to the National Occupational Health and Safety Guidelines on the handling of treated wood products and to local regulations regarding landfill disposal.

Landfill disposal may be permitted under controlled conditions.

Combustion of treated wood should be avoided both because toxic chemicals may be contained in smoke, and soil may be contaminated by the ashes.

Care must also be taken with painted or coated wood waste.



10. Food and Kitchen Hygiene

What are the key steps to preventing food-borne illnesses?

The key steps are:

1. Clean – keep yourself and work areas clean
2. Separate – keep raw meat and other raw animal products away from other foods
3. Cook – always properly cook and prepare foods
4. Chill – store foods appropriately both before and after cooking

What are ways to keep you and work areas clean when handling food?

Poor cleaning and personal hygiene habits/practices can cause food contamination, food poisoning, and spread of infection.

- i. Wash hands before performing the next job function after touching other food, and after smoking, chewing tobacco, eating and drinking, taking out the garbage, changing diapers, touching body parts such as the mouth or going to the washroom.
- ii. Wash hands before and after handling raw food, especially meat and poultry.
- iii. Report immediately any symptoms of illness or infection to your supervisor. It may not be appropriate for you to handle food while you are sick.
- iv. Cover any cuts with a bandage and wear clean gloves. However, do not wear rubber or latex gloves near open flames or other heat sources. Gloves may melt or catch fire. Change gloves if you touch anything that would normally require you to wash your hands.
- v. Wear hair nets to help prevent loose hair from falling on food. The average person loses about 50 hairs per day.
- vi. Use tools or utensils to serve food whenever possible. Touch food with your hands as little as possible.
- vii. Use a clean spoon each time you taste or sample food.
- viii. Touch only the handles of flatware/utensils when setting the table.
- ix. Do NOT wear jewellery in food preparation areas, especially rings; they may collect dirt or bacteria and make it harder to clean your hands. Similarly, keep nails trimmed short and do not wear nail polish.
- x. Do NOT use aprons to dry your hands.

- xi. Do NOT smoke in food preparation areas.
- xii. Use good cleaning and storage techniques to reduce the chance of food borne illnesses. The highest levels of contamination are found in areas that are damp, such as kitchen sponges, dishcloths, sink drains, and faucet handles.
- xiii. Maintain the general cleanliness of the kitchen by:
 - o Disposing of food scraps properly and removing crumbs
 - o Wiping counters clean with soap and water and sanitize with a disinfectant
 - o Sweeping and wet mopping floors to remove food
 - o Cleaning all surfaces, including counter tops, faucets, handles and knobs, refrigerator handles, stoves/ovens, other appliances, etc.
- xiv. Do not store garbage in the food preparation area. If possible, store garbage in a cold place to prevent bacteria growth and pest infestation.
- xv. Inspect kitchen for signs of microbiological growth such as mould, slime, and fungi. Clean the affected area appropriately.
- xvi. Inspect the kitchen for any plumbing leaks. Notify your supervisor to get it repaired.
- xvii. Choose an effective cleaning agent or disinfectant for the job. Most cleaning can be done using water and soap. Some resources will recommend disinfecting with bleach. While bleach is an effective disinfectant, it must be used with care. To sanitize, clean with 5mL (1 tsp) of bleach in 750 mL (3 cups) of water in a labelled spray bottle.
- xviii. Make sure that cleaning equipment and materials are conveniently located close to where they are needed.
- xix. Launder dishcloths, aprons and towels by using a washing machine.
- xx. Clean the food storage area regularly where dry goods, pasta, rice, canned foods, and cereals are stored to prevent buildup of crumbs and other pieces of food.

What are ways to keep foods separated?

To reduce the chances of cross contamination, you should also:

- i. Always use separate cutting boards for raw meat. Cutting boards of either plastic or wood are acceptable. Plastic can be cleaned in a dishwasher. Both types should be disinfected regularly.
- ii. Wipe raw meat, fish or poultry juices using paper towels and then throw out these paper towels. DO NOT REUSE wash cloths after wiping countertops, especially after cleaning up raw meat juice until the cloths have been appropriately laundered.
- iii. DO NOT REUSE any container or bowl that has held raw foods, especially raw meat and poultry, until it has been thoroughly cleaned.

- iv. Wash, rinse, and sanitize cutting boards, utensils, and food probe thermometers before re-using.
- v. Wash the lids of canned foods before opening to keep dirt from getting into the contents. Clean the can opener after each use.
- vi. Store food packages on plates so that their juices do not drip on work surfaces or other food. Place on lower shelves to prevent further contamination.
- vii. Never put cooked food on a plate, cutting board, or a surface that was used for raw meat, poultry, seafood, or eggs without having the surfaces cleaned first.

What are tips for cooking food and to make sure your cooked food is safe?

To reduce bacteria growth:

- i. Thaw food by using the refrigerator, microwave, oven, or by placing sealed packages in cold running water. Never thaw food on the kitchen counter. The outer layers will warm before the inside thaws. Bacteria will grow in these conditions.
- ii. Cook meats to the recommended temperature. Use a clean food probe thermometer.
- iii. Wash fruits and vegetables in running water before preparing, cooking, or eating. It is not necessary to use soap or specialty produce cleaners.
- iv. Serve hot food while hot, or put it in the fridge or freezer as soon as possible once cooled (within two hours of preparation).
- v. Never leave food out for more than two hours, including cut fruits and vegetables.
- vi. Use clean dishes and utensils to serve food. Never use the same ones you used when preparing raw food.
- vii. Keep food on ice or serve it on platters from the refrigerator.
- viii. Divide hot party food into smaller serving platters. Keep platters refrigerated until it's time to warm them up for serving.

What are ways to chill and store food?

Always:

- Keep cooked food warmer than 60°C (140°F) or at 4°C (40°F) or cooler.
- Keep the refrigerator set at 4°C (40°F). If you are unsure of its temperature, use a thermometer and adjust the temperature control as required.
- Keep frozen food at -18°C (0°F) or less. This temperature stops bacterial growth, although it may not kill all bacteria already present before freezing.

Other food storage tips include:

- Put groceries that require refrigeration or freezing in the refrigerator or freezer away as soon as possible after they are purchased.

- Consider using insulated bags during warmer months when transporting food.
- Clean the refrigerator and freezer regularly to remove spoiled foods that may transfer bacteria or molds to other food.
- Do not keep foods too long. Use a dating system to make sure foods are used before their expiry date.
- Do not overstock the refrigerator. Allow the air to circulate freely, which will help keep food cool more effectively.
- Pack lunches in insulated carriers with a cold pack. Do not store the lunch container in direct sun or on a warm radiator.
- If using an esky (e.g at a picnic), keep it cold by using ice or ice packs. Keep the cooler out of direct sunlight. Open the cooler as little as possible. It may be helpful to use a separate cooler for drinks if you will open the cooler for drinks more often.

What are tips to help prevent pest infestations?

- Refuse shipments in which you find pests, such as cockroaches (their egg cases) or mice.
- Remove garbage regularly and properly.
- Keep garbage tightly covered so it does not attract pests.
- Store recyclables as far from your building as local by-laws allow.
- Store all food and supplies away from walls and floors.
- Maintain food storage areas at 50 percent or less humidity. Low humidity helps keep cockroach eggs from hatching.
- Refrigerate foods, such as cocoa, powdered milk, and nuts, that attract insects.
- Keep the equipment used for cleaning dry.
- Clean and sanitize your work area thoroughly after each use.

Are there laws or regulations that apply to when preparing food for the public?

Yes. Wherever food is manufactured, processed, stored, handled, displayed, distributed, sold, or offered for sale, it is important to check with both your local jurisdiction (province or territory) and municipality to find out what laws apply. These rules apply to catering and temporary food events as well. Food safety is enforced by public health inspectors. In some areas, persons handling food may also need a food handling certificate.

11. The Australian Men's Shed Association Policy Statement-Working with Children

Introduction

This document outlines the Australian Men's Shed Association (AMSA) policy guidelines for any Men's Shed that has children and/or young people attending. In this document the terms 'abuse' and 'neglect' refer to:

- Sexual abuse
- Physical abuse
- Emotional or psychological abuse
- Bullying
- Neglect
- Systems abuse

Policy Statement

Many Men's Sheds across Australia are involved in mentoring/intergenerational programmes. In order to keep children and young people safe whilst accessing Men's Sheds, AMSA is committed to protecting children and young people from abuse and neglect. We promote an organisational culture within Men's Sheds that:

- Safeguard children and young people
- Provide Men's Sheds with information about training that enable members and volunteers to become skilled in protecting children and young people.

Objectives

i. A commitment to safeguarding children

Through this statement, the Australian Men's Shed Association (AMSA) documents its clear commitment to safeguarding children and young people.

ii. Personnel roles and conduct

AMSA encourages all Men's Sheds who have a role in mentoring children to ensure that each person involved in the Shed operations understands their role and the behaviour expected in safeguarding children and young people.

iii. Recruitment and screening practices

AMSA encourages all Men's Sheds to have appropriate measures in place to minimise the likelihood that the Men's Shed engages any paid person who is unsuitable to work with children or young people.

iv. Personnel induction and training

AMSA encourages all Men's Sheds to have induction, education and training programmes as a vital part of our commitment to safeguarding children and young people.

v. Involving children, parents and schools

In developing a safe, inclusive and supportive environment AMSA encourages involvement and communication with children, young people, their parents and their school or referring agency. We encourage parental and school involvement and behaviour that helps to protect children and young people.

vi. Child abuse reports and allegations

AMSA encourages each Men's Shed to have measures in place to ensure that all those people who work with children and young people understand their responsibility to report possible abuse or neglect and understand the reporting procedures.

vii. Supporting a child-safe culture

AMSA encourages each Men's Shed to have measures in place to ensure that all those members who work with children and young people understand their responsibility to report possible abuse or neglect and understand the reporting procedures.

viii. Protecting Men's Shed Members

AMSA recognises that by following child safe measures the likelihood of false accusations against any 'shedder' is minimised and therefore adds extra protection for members.

Principles

AMSA encourages each Men's Shed to undertake the principles of this Policy which are to:

- Respect and support the rights of children and young people and be committed to their safety, welfare and wellbeing. In so doing sheds recognise that children and young people have a right to be safe from abuse and neglect.
- Have a responsibility and Duty of Care to ensure all children and young people who access a Men's Shed are kept safe from abuse and neglect at all times.
- Be proactive in ensuring all possible measures and systems are in place to prevent abuse and neglect of children and young people occurring.
- Have strong organisational processes in place that continually monitor how each Men's Shed is doing in keeping children and young people safe from abuse and neglect.
- Act decisively and take appropriate action, using clear policy directions, where and when a Men's Shed finds any abuse or neglect of children and young people has occurred or been alleged in any of the Men's Shed programmes.
- Be prepared to devote whatever skills and resources are appropriate to ensure that shed systems work effectively to prevent and act against the occurrence of abuse and neglect of children and young people.

Policies

AMSA encourages all Men's Sheds to have the following Guidelines in place:

- whenever children/young people are present there will be a minimum of 2 shed members present (in visual sight of) in the same area/space
- No child/young person is to be accompanied to the toilet/bathroom
- Men's Shed members should not have a relationship outside the Men's Shed with any child/young person who attends the Men's Shed (except where there is an existing relationship e.g. grandfather/grandchild)
- Men's Shed members should be vigilant for any suspicious interaction between a Shed members and a child/young person and, if noticed, report immediately to a member of the Management Committee and/or Shed Manager/Coordinator.
- All Shed members and volunteers are to be made aware of these policies.

Code of Conduct

AMSA encourages the following Code of Conduct is adopted and implemented:

Men's Shed members will:

- Follow the 'Working with Children and Young People Policy'
- Treat children and young people with respect, listen and value their ideas and opinions
- Respect cultural, religious and political differences
- Model appropriate adult behaviour
- Listen to children and take action to protect their wellbeing
- Report and act on any breaches of these standards of behaviour
- Respect the privacy of children and their families by only disclosing information to people who have a need to know

Men's Shed members will not:

- Seek to use children in any way to meet the needs of adults
- Use prejudice, oppressive behaviour or language with children
- Discriminate on the basis of age, gender, race, culture, vulnerability or sexuality
- Initiate unnecessary physical contact with children or do things of a personal nature that children can do for themselves
- Develop 'special' relationships with specific children for our own needs
- Show favouritism through provision of gifts or inappropriate attention
- Have a relationship outside the Men's Shed with any child/young person who attends the Men's Shed (except where there is an existing relationship e.g. grandfather/grandchild).

'Working with Children' Checks

NB: Men's Sheds should refer to their individual State requirements and legislation in regards to the legal requirements regarding 'Working with Children' checks.

In Australia, State and Territory governments are responsible for the administration and operation of child protection services. Legislative Acts in each State and Territory govern the way such services are provided.

Men's Shed Management Committees are advised to contact their particular State/Territory Department to obtain guidance and advice. The following table lists the principle Child Protection Acts in each Australian State and Territory, the relevant Department responsible and the website regarding 'Working with Children' checks.

State or Territory	Website
ACT	http://justice.act.gov.au https://www.accesscanberra.act.gov.au/app/answers/detail/a_id/1804/~/working-with-vulnerable-people-%28wwvp%29-registration#!tabs-1
NSW	https://check.kids.nsw.gov.au/
NT	http://www.workingwithchildren.nt.gov.au/
Qld	http://www.ccypcg.qld.gov.au/bluecard/index.html

SA	http://www.police.sa.gov.au/sapol/services/information_requests/police_checks.jsp
Tas.	http://www.dhhs.tas.gov.au/about_the_department/our_plans_and_strategies/future_communities/working_with_children_and_vulnerable_people_screening_unit
Vic.	www.justice.vic.gov.au/workingwithchildren/
WA	www.checkwwc.wa.gov.au/

Reporting

AMSA encourages Men's Sheds to consider that all members and volunteers in child-related interaction are mandatory reporters. They must report to the relevant government department any suspicion or knowledge of a risk of harm to a child or young person, provided they have become aware of the risk through their work with their Men's Shed:

- Unless the urgency of the situation precludes it, prior to making a risk of harm report, all members must discuss the risk of harm issue with their Shed Manager/Coordinator
- When a Risk of Harm report is completed, a copy of the report must be provided to the:
 - AMSA
 - Relevant auspicing agency (if applicable)
 - Men's Shed Manager/coordinator
 - Men's Shed Management Committee
- It is acceptable for a member to make a report jointly with their Men's Shed Committee and this will acquit the reporting obligations of both parties
- AMSA encourages Shed members and volunteers to undertake training in how to recognise the risk of harm to a child or young person.
The relevant State Government Department may be able to support this.

'Reasonable grounds'

'Reasonable grounds' for making a report exist where:

- ✓ *a child tells you he/she has been abused or neglected*
- ✓ *you witness omissions of care towards the child*
- ✓ *someone else tells you that a child has been abused or neglected (e.g. a relative, friend, sibling)*
- ✓ *you become aware of a situation where an adult's behaviour leads you to suspect that the child may be abused or neglected*
- ✓ *you observe that the child has injuries or medical symptoms that could be consistent with physical or sexual abuse or neglect*
- ✓ *a particular child's behaviour leads you to suspect that the child may be abused or neglected*
- ✓ *you observe abusive or neglectful behaviour by a caregiver towards a child*
- ✓ *a child witnesses the abuse of another child or witnesses domestic violence*
- ✓ *you have current concerns that the abuse or neglect may continue or be repeated.*

12. Working With People With A Disability

Introduction

One of the characteristics of Men's Sheds is that many of our members have some kind of disability and we are used to handling such circumstances – where we reasonably can, we adapt. In the shed environment many members have age related disabilities such as the need for glasses, hearing aids, walking aids and so on and some members have more complex disabilities that are more difficult to manage.

Disabilities, permanent or temporary, can arise in so many ways as to make it impossible to develop a policy and set of all encompassing procedures. Indeed the Commonwealth and other legislation can be a bit vague in some parts because of the complexities in covering all possibilities. If the legislation were to be very broadly summarised it is about treating people fairly and equitably whether or not they have a disability.

It is AMSA Policy that members have an opportunity to participate in activities provided it can be done safely and without unduly expensive adaptations that could impact on a shed's viability.

Context for this Policy

Members with a disability are encouraged to let their Shed colleagues know how they can help to overcome situations that might be difficult to manage. This might be a railing, a chair, a modified workbench etc.

From a Men's Shed Health & Safety perspective, it is important that the Induction Risk Assessment that awards a 'Work Capacity' Tag is done properly so that it represents the ability to undertake work in a way which will minimise the risk of harm to the new member and others.

Current members with new / worsening disabilities need to be aware of how the disability affects their safety and the safety of others. These members and or / carers need to advise the Shed member in charge of operations about any significant changes in risk. In such circumstances a revised Work Risk Assessment needs to be undertaken and if necessary a new Tag awarded.

While Men's Shed Health & Safety legislation is non – compromising in many ways, the spirit of Men's Sheds is to examine if there is a way to safely adjust a workplace to suit a disability provided it can be done at a reasonable price and a reasonable timeframe.

If the adjustment is unreasonable from a cost or timeframe perspective to those concerned, then AMSA suggests the proposed adjustments should not proceed and other options considered.

Note: Auspiced Sheds may have alternative Procedures that need to be followed in place of the above AMSA requirements. AMSA requires that Auspiced Sheds guidelines must be compliant with relevant legislation.

12. INCIDENT & NEAR MISS – RECORDING AND REPORTING

Each incident and near miss needs to be recorded and investigated to ensure that the facts are known. This information may be required by Insurers and to communicate issues to other Sheds via AMSA or State bodies to help prevent a reoccurrence.

INCIDENT FORM:

MEN'S SHED	Report No.:
Date of Incident:	Time of Incident:

PART A - WHAT HAPPENED?

Type of Incident:			
<input type="checkbox"/> Injury		<input type="checkbox"/> No-injury	
If Injury:			
<input type="checkbox"/> First Aid		<input type="checkbox"/> Medical Treatment	<input type="checkbox"/> LTI
If No-Injury was the Incident due to:			
<input type="checkbox"/> Fire		<input type="checkbox"/> Explosion	<input type="checkbox"/> Plant
Failure			
<input type="checkbox"/> Plant Damage		<input type="checkbox"/> Other (specify)	
Persons Involved:			
a) Person(s) directly involved.	Member / Name	Address	Phone Number
Damage to plant or property that occurred/may have occurred:			

PART B - HOW DID IT HAPPEN?

Description of Incident: (explain clearly how the incident occurred. This should be brief, in dot point form, providing the facts only and should not contain supposition or hearsay).

Location (attach sketch/map):
Weather Conditions:

PART C - INJURY REPORT

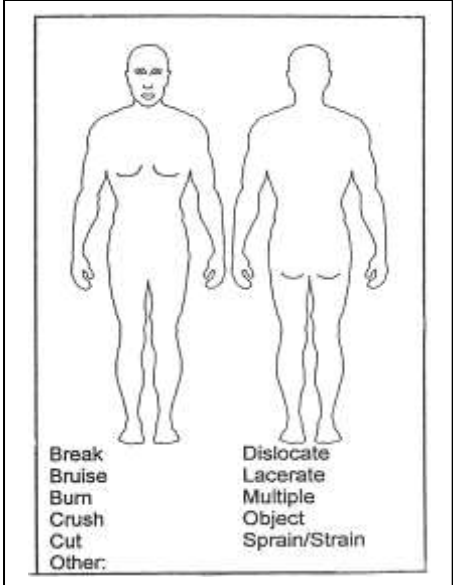
Injury Details:		
Was FIRST AID treatment administered?	YES <input type="checkbox"/> NO <input type="checkbox"/>	
If YES, Treatment details:		
If YES, By whom:		
Was injured person sent to Doctor/Hospital?	YES <input type="checkbox"/> NO <input type="checkbox"/> (Attach Medical Certificate/Certificate of Capacity)	
If YES, name of Doctor/Hospital:		
If YES, name of person taking injured person to Doctor/Hospital:		
Did the Injured person return to shed to participate? YES <input type="checkbox"/> NO <input type="checkbox"/>		

PART D - AUTHORITY NOTIFICATION*

Name of Relevant Authority (Police / Fire / Ambulance):	
Is this a major / serious incident:	YES <input type="checkbox"/> NO <input type="checkbox"/>
If so, has the Authority been notified:	YES <input type="checkbox"/> NO <input type="checkbox"/>

PART E - AUTHORISATION AND DISTRIBUTION

Report Prepared by:		
Name:	Signature:	Date:

DISTRIBUTION OF FORM: TO AMSA

13. SAFE USE OF SPECIFIC EQUIPMENT

ONLY APPROVED OPERATORS ALLOWED TO USE MACHINERY. CHECK GENERAL SAFETY RULES BEFORE OPERATION.

a. *Circular Bench Saw*

Risks:

1. Dangerous saw blade
2. Woodchips & dust in eyes
3. Noise

Safety Controls:

1. Wear GOGGLES
2. Wear EAR MUFFS
3. Use PUSH STICKS

Procedure:

1. Adjust height of safety guard to suit thickness of timber to be sawn
2. Set height of saw blade
3. Check Dust Extractor is ON & Gate OPEN
4. Check position of Fence
5. Switch saw ON
6. Cut timber using PUSH STICKS for small pieces & at the end of the cut
7. Wait for saw to STOP before picking up the pieces
8. Turn saw OFF and close Extractor Gate
9. Clean up



ONLY APPROVED OPERATORS ALLOWED TO USE MACHINERY. CHECK GENERAL SAFETY RULES BEFORE OPERATION.

b. Sliding Compound Saw

Risks:

1. Woodchips in eyes
2. Can cut fingers on blade
3. Kickback from work piece.
4. Noise

Safety Controls:

1. Wear GOGGLES/EAR MUFFS
2. Keep fingers clear
3. Ensure blade at full speed before commencing cut

Procedure:

1. Check guard is in place & functioning satisfactorily
2. Turn on Dust extractor
3. Place timber flat onto cutting bed & clamp into position against fence
4. For long cut pull saw back - keep well above the timber
5. Switch "On" - hold button down until blade has reached full speed
6. Lower and PUSH blade through timber - do NOT pull to cut
7. Release 'On' switch - wait for blade to stop
8. Lift saw & return it to its rest position
9. Remove work piece
10. Clean up



ONLY APPROVED OPERATORS ALLOWED TO USE MACHINERY. CHECK GENERAL SAFETY RULES BEFORE OPERATION.

c. *Small Compound Saw*

Risks:

1. Woodchips in eyes
2. Can cut fingers on blade
3. Kickback from work piece
4. Noise

Safety Controls:

1. Wear GOGGLES/EAR MUFFS
2. Keep fingers clear
3. Ensure blade at full speed before commencing cut

Procedure:

1. Check guard is in place & functioning satisfactorily
2. Turn on Dust extractor
3. Place timber flat onto cutting bed & clamp into position against fence
4. Switch 'On' - hold button down until blade has reached full speed
5. Lower and PUSH blade down through timber
6. Release 'On' switch - wait for blade to stop
7. Lift saw & return it to its rest position
8. Remove work piece
9. Clean up.



ONLY APPROVED OPERATORS ALLOWED TO USE MACHINERY. CHECK GENERAL SAFETY RULES BEFORE OPERATION.

d. Band Saw

Risks:

1. Sawdust in eyes
2. Noise
3. Can cut fingers on blade

Safety Controls:

1. Wear GOGGLES/EAR MUFFS
2. Lower guard to just clear work
3. Do not Trap the blade
4. Use push sticks - not fingers

Procedure:

1. Turn on extractor
2. Lower guard to just clear job- turn saw on
3. Move timber slowly onto blade, following design lines on timber
4. Do not trap the blade or go backwards through the cut
5. For complicated patterns use multiple cuts at different angles
6. If the blade jams - SWITCH OFF before moving the work piece
7. Keep Hands, Fingers & Arms away from the blade
8. Switch 'Off' at the machine & wait for blade to stop
9. Remove work piece
10. Clean up



ONLY APPROVED OPERATORS ALLOWED TO USE MACHINERY. CHECK GENERAL SAFETY RULES BEFORE OPERATION.

e. Table Scroll Saw

Risks:

1. Risk of entanglement
2. Wood Dust in eyes/Noise
3. Saw blade oscillating at high speed

Safety Controls:

1. Eliminate loose clothing/long hair
2. Wear safety glasses/ear muffs
3. Keep hands clear of saw blade

Procedure:

1. Adjust saw blade tension as required
2. Switch on and wait for blade to reach full speed
3. Adjust work piece table and guides
4. Ensure dust extraction on and shut off gate is 'open'
5. Always feed the work slowly into the blade
6. Guide work piece carefully, blade may break
7. Switch off at machine- not at the wall
8. When blade motion ceases, clean up



ONLY APPROVED OPERATORS ALLOWED TO USE MACHINERY. CHECK GENERAL SAFETY RULES BEFORE OPERATION.

f. Router Bench

Risks:

Safety Controls:

1. Woodchips in eyes
2. Rotating cutter very dangerous
3. Kickback from work piece
4. Noise

1. Wear GOGGLES/EAR MUFFS
2. Keep fingers clear of Cutter
3. Wait until Bit rotation stops
4. Follow correct cutting direction

Procedure:

1. Ensure cutter bit is tightly locked in the chuck & free to rotate
2. Lock at the correct height using machine lock & adjustment lock nuts
3. Ensure guards are in place
4. Switch 'On' - allow to reach full speed
5. Check dust extraction is 'On'
6. Hold wood firmly to table - feed edge to cutter - beware of kickback
7. Always feed the work against the direction of rotation of the bit
8. Use repeated small cuts rather than one deep cut
9. Switch off at the machine (not wall) - wait until the bit stops rotating
10. Remove work piece
11. Clean up



ONLY APPROVED OPERATORS ALLOWED TO USE MACHINERY. CHECK GENERAL SAFETY RULES BEFORE OPERATION.

g. Drill Press

Risks:

1. Shavings in Eyes
2. Clothes/hair caught in machine
3. Chuck key left in - can throw out when machine starts

Safety Controls:

1. Wear GOGGLES
2. Wear HAIR COVER
3. Keep HANDS away from drill bit
4. Clamp down work piece

Procedure:

1. Lock drill bit in chuck using chuck key
2. Locate drill bit over target mark. If possible clamp down the work
3. Turn on machine - wait for full speed
4. Using manual lowering arm, move drill through material, backing off to clear swarf if necessary
5. Do not move material during the drilling operation
6. Lift drill to its rest position, turn off & wait until rotation of the bit stops
7. Remove work piece
8. Clean up



ONLY APPROVED OPERATORS ALLOWED TO USE MACHINERY. CHECK GENERAL SAFETY RULES BEFORE OPERATION

h. Belt Sander & Disc Grinder

Risks:

1. Risk of entanglement
2. Wood Dust in eyes/Noise
3. Belt/Disc rotating at high speed

Safety Controls:

1. Eliminate loose clothing/long hair
2. Wear safety glasses/ear muffs
3. Keep hands clear of belt/disc
4. Ensure table secure

Procedure:

1. Adjust disc table as required
2. Switch on and wait for belt/disc to reach full speed
3. Adjust work piece gauges and guides
4. Ensure dust extraction on and shut off gate is 'open'
5. Always feed the work against the rotation of the belt
6. Hold Work piece lightly in position on belt/disc- beware of 'kick back'
7. Switch off at machine- not at the wall
8. When belt rotation stops, clean up



ONLY APPROVED OPERATORS ALLOWED TO USE MACHINERY. CHECK GENERAL SAFETY RULES BEFORE OPERATION.

i. Wood Lathe

Risks:

Safety Controls:

1. Risk of entanglement
2. Wood Chips in eyes/Noise
3. Work/Chuck rotating at speed
4. Work piece can fly out at start-up

1. Eliminate loose clothing/long hair
2. Wear safety glasses/ear muffs
3. Keep hands clear of work/chuck.
4. Check work piece position, centre and rotation of direction prior to start

Procedure:

1. Seek instruction if not fully familiar with the wood lathe
2. Adjust and centre the work piece before work
3. Ensure chuck installed correctly and adjusted for work piece
4. Lock Tail Stock and Tool Rest in position
5. Set rotation speed and direction appropriate for the work
6. Ensure dust extraction on and shut off gate is “open”. Position chip collector
7. Switch on and wait for work to reach set speed
8. Make small cuts with appropriate hand tool or chisel
9. Keep work area as clear as possible and free of large quantities of chips
10. Switch off at machine then at the wall if finished work for the day
11. Clean up



ONLY APPROVED OPERATORS ALLOWED TO USE MACHINERY. CHECK GENERAL SAFETY RULES BEFORE OPERATION.

j. Spindle Moulder

Risks:

1. Wood Chips in eyes/Noise
2. Cutters rotating at high speed
3. Striking
4. Kickback from work piece

Safety Controls:

1. Wear safety glasses/ear muffs
2. Keep fingers clear of cutters
3. Ensure guards are in place
4. Wait for cutter to stop
5. Ensure tooling is secure in spindle
6. Follow correct cutting direction

Procedure:

1. Ensure that the cutter tooling is secure in the spindle
2. Adjust work piece gauges and guides
3. Ensure guards are in place
4. Ensure dust extraction on and shut off gate is 'open'
5. Switch on and wait for cutter to reach full speed
6. Always feed the work against the rotation of the cutter
7. Hold work piece in position against guides- beware of 'Kick Back'
8. Use push sticks where required for small work pieces
9. Switch off at machine. Not at the wall
10. When cutter rotation stops, remove work piece
11. Clean up



ONLY APPROVED OPERATORS ALLOWED TO USE MACHINERY. CHECK GENERAL SAFETY RULES BEFORE OPERATION.

k. Planer/Thicknesser

Risks:

1. Risk of entanglement
2. Wood Chips in eyes/Noise
3. Cutters rotating at high speed
4. Striking
5. Kickback from work piece

Safety Controls:

1. Eliminate loose clothing/long hair
2. Wear safety glasses/ear muffs
3. Keep hands clear of cutters
4. Ensure guards are in place
5. Do not stand behind work piece
6. Follow correct cutting direction

Procedure:

1. Adjust depth of cut for light pass-make small cuts
2. Adjust work piece gauges and guides
3. Ensure guards are in place
4. Ensure dust extraction on and shut off gate is 'open'
5. Switch on and wait for cutter to reach full speed
6. Always feed the work against the rotation of the cutter
7. Hold Work piece in position against guides-beware of 'Kick Back'
8. Use push sticks where required for small work pieces
9. Switch off at machine- not at the wall
10. When cutter rotation stops, remove work piece
11. Clean up



ONLY APPROVED OPERATORS ALLOWED TO USE MACHINERY. CHECK GENERAL SAFETY RULES BEFORE OPERATION.

1. Planer/Jointer

Risks:

1. Risk of entanglement
2. Wood Chips in eyes/Noise
3. Cutters rotating at high speed
4. Injury to hands
5. Kickback from work piece

Safety Controls:

1. Eliminate loose clothing/long hair
2. Wear safety glasses/ear muffs
3. Keep hands clear of cutters
4. Ensure guards are in place
5. Do not pass hands over cutter
6. Do not stand behind work piece

Procedure:

1. Adjust depth of cut for light pass- make small cuts
2. Adjust work piece gauges and guides
3. Ensure guards are in place
4. Ensure dust extraction on and shut off gate is 'open'
5. Switch on and wait for cutter to reach full speed
6. Always feed the work against the rotation of the cutter
7. Hold Work piece in position against guides. Beware of 'kick back'
8. Use push sticks where required for small work pieces
9. Switch off at machine - not at the wall
10. When cutter rotation stops, remove work piece
11. Clean up



ONLY APPROVED OPERATORS ALLOWED TO USE MACHINERY. CHECK GENERAL SAFETY RULES BEFORE OPERATION.

m. Mini Milling Drilling Machine

Risks:

1. Risk of entanglement
2. Injury, cutting, stabbing etc
3. Tool rotating at high speed
4. Striking injury
5. Swarf in eyes/Noise

Safety Controls:

1. Eliminate loose clothing/long hair
2. Machine isolated before adjustment
3. Keep hands clear of tooling
4. Check work piece & tooling are secure
5. Wear safety glasses/ear muffs

Procedure:

1. Seek instruction if not fully familiar with the Mini Drill/Mill
2. Ensure rotation direction set and correct
3. Secure work piece to the work table
4. Ensure that vertical axis assembly set upright or to appropriate angle
5. Select the right cutting tool for the job
6. Adjust and secure tooling in chuck and position
7. Switch on and wait for chuck to reach full speed. Adjust speed as required
8. Engage tooling smoothly and slowly- make small cuts
9. Switch off at machine - not at the wall
10. When cutter rotation stops, remove work piece
11. Clean up



ONLY APPROVED OPERATORS ALLOWED TO USE MACHINERY. CHECK GENERAL SAFETY RULES BEFORE OPERATION.

n. Panbrake/Folder/Guillotine & Roll

Risks:

1. Injury, cutting, stabbing etc
2. Striking injury
3. Shearing injury
4. Crushing injury

Safety Controls:

1. Wear gloves to prevent cuts from sharp material off-cuts.
2. Take care handling blades
3. Ensure material clamps adjusted
4. Keep hands clear of blades and rolls
5. Secure machine and work

Procedure:

1. Seek instruction if not fully familiar with the folder/guillotine
2. Ensure work piece within tolerances for this machine
3. Material maximum for shear/brake/fold 1mm steel. (30" wide)
4. Position work for fold, shear or roll
5. Test machine motion and clamping prior to full operation
6. Apply steady rotation to the handles. Assistance may be required for some jobs
7. When machine action stops, remove work piece
8. Clean up



ONLY APPROVED OPERATORS ALLOWED TO USE MACHINERY. CHECK GENERAL SAFETY RULES BEFORE OPERATION.

o. Metal Lathe

Risks:

1. Risk of entanglement
2. Injury, cutting, stabbing etc
3. Chuck rotating at high speed
4. Striking injury
5. Swarf in eyes/Noise

Safety Controls:

1. Eliminate loose clothing/long hair
2. All guards in position.
3. Machine is electrically isolated before adjustment
4. Keep hands clear of chuck
5. Check work piece & tooling are secure
6. Wear safety glasses/ear muffs

Procedure:

1. Seek instruction if not fully familiar with the AL60 metal lathe
2. Ensure guards are in place
3. Ensure rotation direction set and correct
4. Secure work piece in the chuck and lock
5. Select the right cutting tool for the job
6. Adjust and secure tooling and tail stock in position
7. Switch on and wait for chuck/work to reach full speed
8. Engage tooling smoothly and slowly - make small cuts
9. Switch off at machine - not at the wall
10. When cutter rotation stops, remove work piece
11. Clean up



p. Wood Turning Lathe

What should you do before using a wood turning lathe?

- A wood turning lathe can be dangerous if not used properly.
 - Read the owner's manual carefully.
 - Make sure you understand instructions before attempting to use any tool or machine. Only experienced and trained lathe operators should be allowed to operate lathes.
 - Learn the applications and limitations before use.
 - Refer to Woodworking Machines - General Safety Tips for general safety precautions.
-

What safety procedures should you follow when using a wood turning lathe?

- Wear safety glasses or goggles, or a face shield (with safety glasses or goggles) to protect yourself from flying chips.
- Wear hearing protection that is suitable for the level and frequency of the noise you are exposed to in the woodworking area.
- Wear a dusk mask when dust is generated (e.g., during sanding operations).
- Wear protective footwear when required.
- Work in well-lighted area.
- Before the lathe is turned on, ensure that all clamps and fittings are secure and that the work piece is free to turn.
- Use stock free of defects.
- Hold tools firmly with both hands and against the tool rest.
- Hold the stock securely on the faceplate or between the centres.
- Use only furnished or approved tools.
- Use sharp, well-maintained chisels and gouges.
- Select a speed that is appropriate for the job. Operate the lathe at a low speed and use a moderate cut depth to prevent splinters from flying out during roughing operations. The actual speed of the lathe depends on type of wood, a diameter of stock, nature of work being done and type of tool used.
- Adjust tool rests so that they are parallel and as close as possible to the stock. They should also be set high enough so that tools will cut into the wood slightly above the centre of the work being turned.
- Remove the tool rest when sanding or polishing.
- Use appropriate tools to hold the sand paper or emery paper whenever possible. Examples include a 'nut cracker' or the paper fixed to a piece of flat wood. If you must use your hands always hold the paper in a way that will not allow the paper to catch, pull or entangle around the stock.

- To make a faceplate turning, the one hand steadies the tip of the chisel, which holds the edge against the tool rest while the other hand guides the tool. Keep the tip of the chisel held higher than the handle.



What should you avoid when working with a woodturning lathe?

- Do not wear gloves, loose clothing, rings or jewellery around the neck that can hang outside one's clothing. Clothing should be comfortable but not so loose that it can catch on the machine or get entangled with any rotating parts or the wood being turned; shirts should be tucked in and long hair tied back.
- Do not leave a running lathe unattended - leave only after the lathe has been turned off and it has come to a complete stop.
- Do not use makeshift tools.
- Do not use stock containing checks, splits, cracks, or knots.



q. Woodworking Machines

What should you do before using woodworking machines?

- Woodworking tools can be dangerous if not used properly.
 - Only use woodworking machines that you have been trained to use properly and safely.
 - Read the owner's manual carefully.
 - Make sure you understand instructions before attempting to use any tool or machine. Ask questions if you have any doubts about doing the work safely.
-

What safety procedures should you follow when using woodworking machines?

- Always wear safety glasses or goggles, or a face shield (with safety glasses or goggles).
- Wear hearing protection that is suitable for the level and frequency of the noise you are exposed to in the woodworking area. If you have trouble hearing someone speak from three feet away, the noise level from the machine is too high. Damage to hearing may occur.
- Use gloves to protect hands from splinters when handling wood but do not wear them near rotating blades and other machinery parts where the gloves can catch.
- Wear protective footwear when required.
- Make sure the guard is in position, is in good working condition, and guards the machine adequately before operating any equipment or machine. Check and adjust all other safety devices.
- Make sure the equipment is properly grounded before use.
- Check that keys and adjusting wrenches are removed from the machine before turning on the power.
- Inspect stock for nails or other materials before cutting, planing, routing or carrying out similar activities.
- Make sure that all machines have start and stop buttons within easy and convenient reach of an operator. Start buttons should be protected so that accidental contact will not start the machine. A collar around the button 3 to 6 mm (1/8 to 1/4 inch) above the button is recommended.
- Ensure that all cutting tools and blades are clean, sharp, and in good working order so that they will cut freely, not forced.
- Turn the power off and unplug the power cord (or lock out the power source) before inspecting, changing, cleaning, adjusting or repairing a blade or a machine. Also turn the power off when discussing the work.
- Use a "push stick" to push material into the cutting area. Jigs are also useful in keeping hands safe during cutting procedures. Keep hands out of the line of the cutting blade.
- Clamp down and secure all work pieces when drilling or milling.

- Use good lighting so that the work piece, cutting blades, and machine controls can be seen clearly. Position or shade lighting sources so they do not shine in the operator's eyes or cause any glare and reflections.
 - Ensure that the floor space around the equipment is sufficient to enable you to machine the size of work piece being processed safely without bumping into other workers or equipment.
 - Use extension tables or roller supports for large workpieces. Supports should be placed on both sides (infeed and outfeed).
 - Woodworking machines should be fitted with efficient and well-maintained local exhaust ventilation systems to remove sawdust or chips that are produced.
 - Electric power cords should be above head level or in the floor in such a way that they are not tripping hazards.
 - Keep work area free of clutter, clean, well swept, and well lit. Spills should be cleaned up immediately. Floor areas should be level and non-slip. Good housekeeping practices and workplace design will reduce the number of injuries and accidents from slips, trips, and falls.
-

What should you avoid when working with woodworking machines?

- Do not wear loose clothing, work gloves, neckties, rings, bracelets or other jewellery that can become entangled with moving parts.
- Avoid awkward operations and hand positions where a sudden slip could cause your hand to move into the cutting tool or blade.
- Do not remove sawdust or cuttings from the cutting head by hand while a machine is running. Use a stick or brush when the machine has stopped moving.
- Do not use compressed air to remove sawdust, turnings, etc. from machines or clothing.
- Do not leave machines running unattended (unless they are designed and intended to be operated while unattended). Do not leave a machine until the power off is turned off and the machine comes to a complete stop.
- Do not try to free a stalled blade before turning the power off.
- Do not distract or startle an operator while he or she is using woodworking equipment.
- Horse play should be prohibited. It can lead to injuries.

r. Safe Use of Radial arm saw

What should you do before using a radial arm saw?

- A radial arm saw can be dangerous if not used properly.
 - Read the owner's manual carefully.
 - Make sure you understand instructions before attempting to use any tool or machine.
 - Learn the applications and limitations before use.
-

What safety procedures should you follow when using a radial arm saw?

- Wear safety glasses or goggles, or a face shield (with safety glasses or goggles).
- Wear hearing protection that is suitable for the level and frequency of the noise you are exposed to in the woodworking area.
- Wear protective footwear when required.
- Feed stock against the direction of the blade (the blade should move downward when viewed by the operator).
- Only use saw blades rated at or above the speed of the saw arbour. (An arbour is the attachment from motor to blade)
- Use only the accessories designed for that specific saw and application.
- Ensure the guard consists of two parts:
 - Upper hood type that covers arbour
 - Lower guard that rides on the stock, adjusting automatically to the thickness being cut.
- Stand on the handle side when cross cutting. Pull the cutting head with the hand nearest the handle and manoeuvre the stock with the other hand.
- Make sure the hand holding the stock is never in line with the blade.
- Return the cutting head completely to the back of the saw table after each cut. The saw should be designed so that the blade will not move forward under its own weight or if the machine is vibrating.
- When ripping, make sure the overall length of the saw table (both infeed and outfeed) is twice the length of the longest pieces of timber.
- When ripping, make sure that the stock is fed against the direction of the blade (from the side where the saw blade rotates upward toward the operator). The blade should extend slightly into the table. The motor head must be locked at the correct height and angle.
- Clamp stock to the table on one side of the saw blade, when making mitre, bevel or compound mitre cuts. Clamping prevents the wood from sliding along the fence during the cut.
- Turn off the saw when making any adjustments or changes in the set up.

- Make measurements by placing the wood to be cut against the stop gauge. When measuring with a tape measure or ruler is necessary, turn off the saw until the measuring is complete.

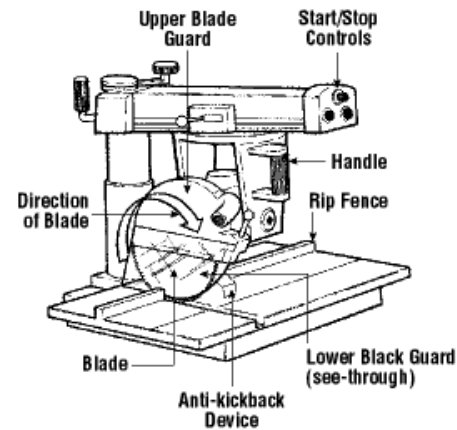

What should you avoid when working with a radial arm saw?

- Do not use radial arm saws for ripping unless the spreader (riving knife) and anti-kickback devices are provided and properly adjusted.
- Do not take your hand away from the operating handle unless the cutting head is behind the fence.
- Do not remove the stock from a saw table until the blade has been returned to its "resting" position at the back of the saw table. Use a stick or brush to remove scrap from the saw table.
- Do not cut "free hand". Use the back guide or fence, or other device to keep the workpiece from moving.
- Do not use cracked or dull blades.
- Do not leave a running saw unattended - leave only after the saw has been turned off and it has come to a complete stop.

s. Table Saw

What should you do before using a table saw?

A table saw can be dangerous if not used properly.

- Read the owner's manual carefully.
 - Make sure you understand instructions before attempting to use any tool or machine.
 - Learn the applications and limitations before use.
-

What safety procedures should you follow when using a table saw?

Wear safety glasses or goggles, or a face shield (with safety glasses or goggles).

- Wear hearing protection that is suitable for the level and frequency of the noise you are exposed to in the woodworking area.
- Wear protective footwear when required.
- Pay particular attention to the manufacturer's instructions on reducing the risk of kickback (when the wood can be violently thrown back toward the operator).
- Choose proper blades for the type of work being done.
- Keep blades clean, sharp, and properly set so that they will cut freely without having to force the work piece against the blade.
- Use the guards provided with the saw or ones designed for use with the saw that you are using. Keep them in place and in good working condition.
- Use a guard high enough to cover the part of the blade rising above the stock and wide enough to cover the blade when it is tilted. The blade height should be set so it does not extend more than about 3 mm (1/8 in) above the height of the piece being cut.
- Ensure that the fence is locked in position after the desired width has been set.
- Hold the work piece firmly down on the table and against the fence when pushing the wood through.
- Ensure that there is adequate support to hold a work piece; use extension tables or roller supports at the side or back for larger pieces. If an assistant is at the back (outfeed) end of the saw, an extension table should be in place so the back edge is about 1.2 m (4 ft) from the saw blade. The assistant should wait for the work piece to reach the edge of the extension table and should not reach toward the saw blade.
- Feed stock into the blade against the direction of its rotation.
- Move the rip fence out of the way when cross cutting. Never use it as a cut off gauge.
- Use a push stick when ripping narrow or short stock (e.g., when the fence is set less than about 15 cm (6 in) from the blade; when the piece is less than 30 cm (12 in) long or when the last 30 cm (12 in) of a longer piece is being cut). Refer to ripping applications in the manufacturer's instruction manual. See Woodworking Machines - Push Sticks for more information on push stick design.

- Use the push stick to remove the cut piece from between the fence and the blade.
- Keep hands out of the line of a saw blade.
- Use guard with a spreader (riving knife) and anti-kickback fingers for all ripping or cross cutting operations.
- Keep the body and face to one side of the saw blade out of the line of a possible kickback.
- Provide adequate support to the rear and sides of a saw table for wide or long stock.
- Be careful when waxing, cleaning, or servicing the table. Shut off and unplug (or lock out) a saw before doing any work on the saw.
- Keep area clean and clutter-free. Operate machines in a non-congested, well-lit area.
- Use the proper sawdust exhaust systems as required by operation.

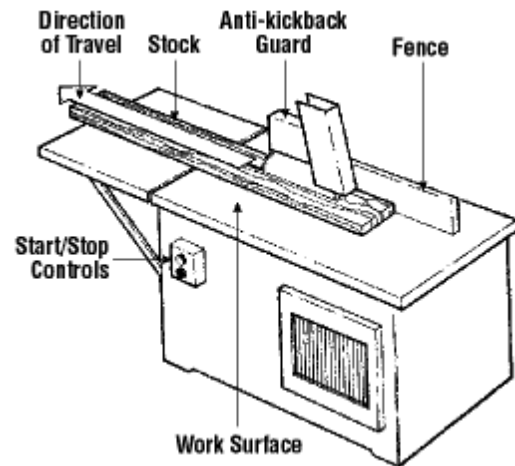

What should you avoid when working with a table saw?

- Do not saw freehand. Always hold the stock firmly against the mitre gauge or a rip fence to position and guide the cut.
- Do not reach around and over moving blades.
- Do not feed the work piece faster than the
- Do not leave a saw running unattended. Turn off the power and make sure the machine has stopped running before leaving the area.

t. Mitre Saw

What should you do before using a mitre saw?

- Mitre saws can be dangerous if not used properly.
 - Read the owner's manual carefully.
 - Make sure you know and understand the instructions before attempting to use any tool or machine.
 - Learn the applications and limitations before use.
-

What safety precautions should you follow when using a mitre saw?

- Wear safety glasses or goggles, or a face shield (with safety glasses or goggles).
- If work is dusty, use a respirator or dust mask.
- Wear appropriate hearing protection.
- Wear protective footwear when required.
- Attach the saw firmly on a workbench or other rigid frame and operate saw at waist height. The saw can also be taken to remote locations by mounting it on a piece of plywood 13 mm (1/2 in.) or thicker. This must be clamped to a waist high work surface on the job site with large "C" clamps.
- Keep one hand on the trigger switch and handle and use the other hand to hold the stock against the fence.
- Keep hands out of the path of the blade.
- Keep guards in place and in working order.
- Remove adjusting keys and wrenches.
- Use a crosscut or combination blade.
- Ensure that the blade rotates in the correct direction.
- Ensure that the blade and arbour collars are secure and clean. Recessed sides of collars should be against blade.
- Keep blade tight, clean, sharp and properly set so that it cuts freely and easily.
- Allow motor to reach full speed before cutting.
- Follow instructions for lubricating and changing accessories.
- Keep the work area clean. Cluttered areas and benches invite accidents.
- Keep the work area well lit.
- Reduce the risk of unintentional start-up. Make sure saw switch is in OFF position before plugging in.
- Unplug tools before servicing and when not in use.
- Check for damage. Repair or replace damaged parts.
- Keep motor air slots clean and free of chips.
- Use only the accessories designed for the specific saw and job.

What should you avoid when using a mitre saw?

- Do not operate the saw on ground.
- Do not cut pieces smaller than 20 cm (8 in.) in length.
- Do not cut "free hand." The stock should lie solidly on the table against the fence.
- Do not reach around or behind the saw blade.
- Do not take your hand away from the trigger switch and handle until the blade is fully covered by the lower blade guard.
- Do not overreach. Keep proper footing and balance at all times.
- Do not force the saw. The saw cuts better and more safely at the rate for which it was designed.
- Do not leave the saw until it has stopped completely. Turn the power off and unplug the saw.
- Do not use electric tools in damp or wet locations.
- Do not operate electric tools near flammable liquids or in gaseous or explosive atmospheres. Sparks may ignite fumes.

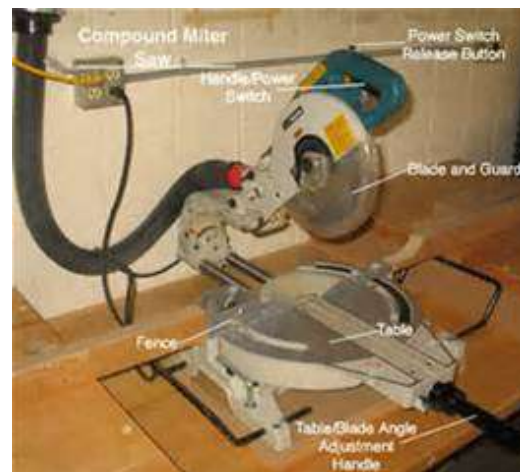

14. Safe Use of Specific Equipment - hand tools

a. Safe Use of Spanners and wrenches

What kinds of wrenches are there?

Wrenches are made in various shapes and sizes and are used for gripping, fastening, turning, tightening and loosening things like pipes, pipe fittings, nuts and bolts. There basically two major kinds of wrenches:

- Pipe wrenches used in plumbing for gripping round (cylindrical) things.
- General use wrenches used on nuts and bolts that have flat, parallel surfaces; e.g., square or hexagonal (hex).

Wrenches may be adjustable to fit different sized pipes, nuts and bolts or may be a fixed size.

What are some examples of adjustable wrenches?

Adjustable wrenches include:

- Pipe wrenches.
 - Crescent (TM) wrenches which have adjustable jaws set at a 30 degree angle from the handle. Although Crescent is a trade name, it is widely used to refer to any regular adjustable wrench with an angled jaw regardless of who manufactured it.
 - Monkey wrenches which have their adjustable head at a 90 degree angle from the handle.
-

What are some examples of fixed-size wrenches?

Fixed-sized wrenches include:

- Open ended wrenches that have "jaws" with parallel sides or tines that fit snugly on nuts and bolts.
- Closed end or box wrenches that have a loop at the end with notches on the inside that allow the wrench to fit either square or hex nuts or both (depending on the number of notches or points).
- Combination wrenches that have both an open end and a closed end on either end of the wrench; usually they fit the same size nut or bolt.
- Socket wrenches are like closed end wrenches except they are cylindrical in shape. They can fit over a nut in a recessed hole that would be inaccessible with open or closed ended wrenches. These have an offset handle at right angles to the nut being tightened or loosened. Usually the handle is a ratchet-type handle that allows the user to turn the socket continuously in one direction by moving the handle back and forth without having to take the socket off the nut.
- Torque wrenches, one type of socket wrenches, have a built-in spring-loaded indicator that shows how much torque being is being applied (i.e., shows how hard the nut is being tightened).
- Nut drivers, another type of socket wrenches, are sockets that can be snapped on or permanently fixed to a screwdriver-type handle.

- Allen wrenches or Allen keys are hexagon-shaped (six-sided) metal shafts that are bent into an L-shape for leverage. Hex drivers are "straight Allen wrenches" that have a screwdriver-type handle. These are different from the other wrenches since they fit inside a recessed hexagonal hole in screw heads instead of around a nut or bolt.

Fixed wrenches fit single, specific sizes. Metric wrench sizes are expressed as whole numbers (e.g., 8, 10, 14, 32) that correspond to the sizes in millimetres. Non-metric sizes used widely in the U.S. are also called S.A.E (Society of Automotive Engineers) sizes and are expressed as fractions of an inch; e.g., 1/4, 1/2, 3/4, 1 1/4. Since both metric and S.A.E. fasteners (nuts, bolts, etc.) are used in Canada, users must select the correct type and size of wrench to prevent injuries and damage to equipment in case of slippage when force is applied to the wrench.

What are general safety tips when using wrenches?

- Use the correct wrench for the job - pipe wrenches for pipes plumbing fittings, and general use wrenches for nuts and bolts.
- Discard any damaged wrenches (e.g., open ended wrenches with spread jaws or box wrenches with broken or damaged points).
- Select the correct jaw size to avoid slippage.
- Wear safety glasses or a face shield (with safety glasses or goggles) where there is a likely hazard of flying particles or falling debris.
- Position your body in a way that will prevent you from losing balance and hurting yourself if the wrench slips or something (e.g., a bolt) suddenly breaks.
- Use a box or socket wrench with a straight handle, rather than an off-set handle, when possible.
- Ensure that the jaw of an open ended wrench is in full contact (fully seated, "flat", not tilted) with the nut or bolt before applying pressure.
- When turning with an adjustable wrench, the direction of the turn should be against (towards) the permanent jaw.
- Ensure that the teeth of a pipe wrench are sharp and free of oil and debris and that the pipe or fitting is clean to prevent unexpected slippage and possible injuries.
- Apply a small amount of pressure to a ratchet wrench initially to ensure that the ratchet wheel (or gear) is engaged with the pawl (a catch fitting in the gear) for direction you are applying pressure.
- Support the head of the ratchet wrench when socket extensions are used.
- Pull on a wrench using a slow, steady pull; do not use fast, jerky movements.
- Stand aside when work is done with wrenches overhead.
- Make sure adjustable wrenches do not "slide" open during use.
- Keep tools well maintained (cleaned and oiled).
- Clean and place tools and wrenches in a tool box, rack or tool belt after use.

What should I avoid doing when using wrenches?

- Do not use push on a wrench - losing your balance is more likely if the wrench slips.
- Do not use a wrench that is bent handle or damaged.
- Do not use worn adjustable wrenches. Inspect the knurl, jaw and pin for wear.
- Do not pull on an adjustable wrench that is loosely adjusted.
- Do not use pipe wrenches on nuts or bolts.
- Do not use pipe wrenches for lifting or bending pipes.
- Do not use a wrench on moving machinery.
- Do not use the wrong tools for the job. Never use pliers instead of a wrench or a wrench as a hammer.
- Do not use a make-shift wrench.
- Do not insert a shim in a wrench for better fit.
- Do not strike a wrench (except a "strike face" wrench) with a hammer, or similar object, to gain more force.

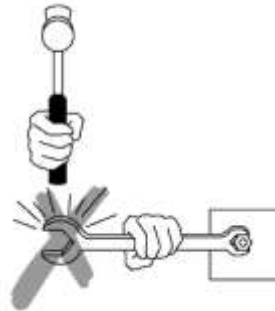

- Do not increase the leverage by adding sleeved additions (e.g., a pipe) to increase tool handle length.
- Do not expose a wrench to excessive heat (like from a blow torch) that could affect the temper of the metal and ruin the tool.

b. Gear Pullers

What are some safety tips for using gear pullers?

Gear pullers are made in various shapes and sizes and have many uses. Always use the correct tool for the job.

- Wear safety glasses or goggles, or a face shield (with safety glasses or goggles).
- Select the proper gear puller for each job. Always use a gear puller of the required size or larger. Use a 3-jaw puller, if possible.
- Ensure that the gear puller is aligned with the shaft and fits tightly around the part to be removed. The jaws should be parallel with the screw. This assures a straight pull.
- Be careful when removing a stubborn gear or bearing. Always strike the head of the centre screw squarely. If after two sharp blows the gear or bearing remains stuck, select a larger puller and proceed to remove the gear or bearing.
- Use a protective cap or removable point to protect screw from mushrooming or splitting.
- Stop work if the gear puller starts to deform.
- Cover work with a cloth to protect you and by-standers from flying parts.
- Lubricate the centre screw with machine oil before use.
- Clean the gear puller after use and store it in a dry place.

What are some things that I should avoid doing?

- Do not use air powered tools on gear pullers.
- Do not use any puller with functioning parts that show excessive wear, dents, or cracks. Inspect the centre screw for signs of galling or seizing.
- Do not heat any gear puller. It will lose its strength and break under pressure if heated.
- Do not cut or grind any part of a gear puller.

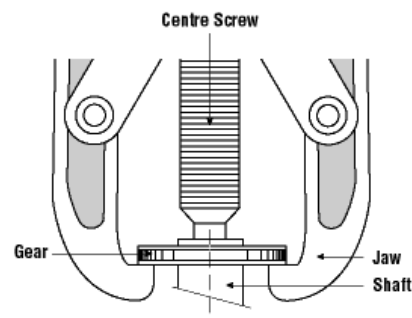

c. Vices

What should I know about using a vice?

A vice, sometimes called the third hand, is an indispensable tool in the tool room or workshop. Vices are usually mounted on workbenches or similar firm supports to hold material in place. Most vices can be used for a wide variety of work. Select the most suitable vice which is strong enough for the work.

- Wear safety glasses or goggles, or a face shield (with safety glasses or goggles) when using striking tools or power tools on a workpiece held by a vice.
- Attach a vice securely. Place bolts in all the holes in the base of the vice. Use lock washers under the nuts.
- Mount a vice so that the stationary jaw projects slightly beyond the edge of the workbench. This allows long work to be clamped in the vice without interference from the edge of the workbench.
- Ensure that the workbench is firmly secured to its base.
- Check the vice for cracks or other damage before clamping a workpiece in it.
- Use a vice large enough to hold the work without strain.
- Place the work piece in the vice so that the full clamping surface of the jaw supports the workpiece
- Keep the work piece in the vice close as possible to the jaws to prevent vibration when sawing, filing, etc.
- Support the end of extra-long work with an adjustable stand, saw horse, or box rather than putting extra strain on the vice.
- Keep all threaded and moving parts clean, oiled and free of chips and dirt.
- Use jaw liners in a vice where there is any possibility of marking the work.
- Replace a bent handle and worn jaw inserts.

What should I not do?

- Do not weld the base of the vice to any metal
- Do not repair a vice by welding or brazing
- Do not try to bend a heavy rod in a light vice.
- Do not cut into the jaws.
- Do not apply heavy pressure at the corner of the vice jaws.
- Do not use a handle extension (e.g., a pipe) for extra clamping pressure.
- Do not hammer on the handle to tighten beyond hand pressure.
- Do not use the jaws of the vice as an anvil.
- Do not use any vice that has the slightest crack.
- Do not unscrew or open the jaws of the vice wider than they were designed to be used.

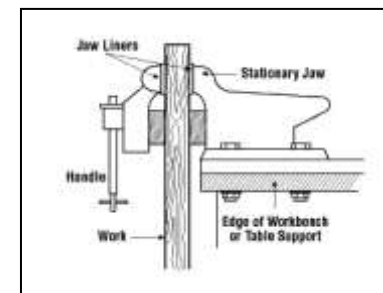

d. Wood Chisels

What are some safety tips to know when using a wood chisel?

Wood chisels are made in various shapes and sizes and for many uses. Use the correct chisel for the job.

- Wear safety glasses, or goggles, or a face shield (with safety glasses or goggles).
- Use the right size of chisel for the job.
- Choose smooth, rectangular handles that have no sharp edges and are attached firmly to the chisel.



- Ensure that the cutting edge is sharp. Dull chisels can be difficult to control and require more effort to do the job.
- Check stock thoroughly for knots, staples, nails, screws or other foreign objects before chiselling.
- Clamp stock so it cannot move.
- Adjust your stance so that you do not lose your balance if the tool slips.
- Chip or cut away from yourself.
- Keep your hands and body behind the cutting edge.
- Use a wooden or plastic mallet with a large striking face on all chisels. Only heavy-duty or framing chisels are made of a solid or moulded handle that can be struck with a steel hammer.
- Make finishing or paring cuts with hand pressure alone.
- Place chisels safely within the plastic protective caps to cover cutting edges when not in use.
- Replace any chisel that is bent or shows dents, cracks, chips, or excessive wear.
- Store chisels in a "storage roll," a cloth or plastic bag with slots for each chisel, and keep them in a drawer or tray.
- Replace broken or splintered handles.
- Sharpen cutting edges as often as necessary.

What should I avoid doing?

- Do not use a wood chisel as a pry or a wedge.
- Do not use a wood chisel on metal.
- Do not use an all-steel chisel with a mushroomed face or a chipped edge. Redress with a file or whetstone.
- Do not use a grinder to redress heat-treated tools. Use a whetstone.
- Do not use a dull chisel.

e. Clamps

What are examples of clamps?

Clamps are versatile tools that serve to temporarily hold work securely in place. They are used for many applications including carpentry, woodworking, furniture making, welding, construction and metal working.

Clamp styles include C-clamps, bar clamps, pipe clamps, and hand-screws. Bar clamps have adjustable arms that are easily widened or narrowed to fit the work piece and, therefore, requires fewer turns of the screw spindle, compared to a C-clamp, to hold the piece tightly.

Proper use of a **bar clamp**:

- Used for woodwork, especially for holding edges when gluing.
- Apply clamping pressure at right angles to the glue line otherwise slippage may result.

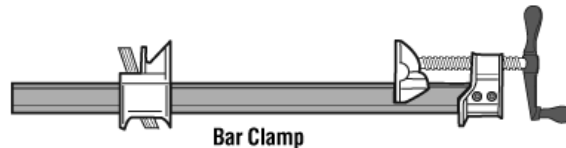

Proper use of a **c-clamp**:

- Used for carpentry, welding or cutting.

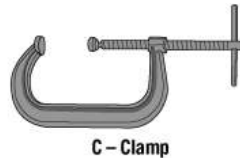

Proper use of a **hand screw clamp**:

- Can be made of metal or wood.
- Used to hold small pieces or in furniture repair.



What are some general safety tips to know when using clamps?

- Wear safety glasses or goggles, or a face shield (with safety glasses or goggles).
- Select the proper clamp style and size by matching the work-holding requirements of the job with the following clamp features:
- strength and weight (e.g., consider rail size and nominal clamping pressure)
- opening (length of reach)
- throat depth (depth of reach)
- ease of adjustment
- clamping surfaces (material used and size)
- Ensure that the swivel at the end of the screw turns freely before using.
- Dispose of clamps with bent frames; replace bent spindles, if possible.
- Ensure that the pressure plate and anvil parts of the clamp are in full contact with the workpiece before tightening.
- Close the jaws until the clamp feels tight. For example, when gluing, some glue will be squeezed out, a sign that it is tight enough.
- Use pads with C-clamps to avoid marking the work.



- Remove clamps as soon as the job is finished. Clamps serve only as temporary devices for holding work securely in place.
- Keep all moving parts of clamps lightly oiled and keep tools clean to prevent slippage. Also make sure there is no dirt or oil on any part that will come in to contact with the work.
- Store C-clamps by clamping them in a rack, not in a drawer.

What should I avoid doing?

- Do not use extra-large clamps just for the sake of their large throats. Instead, use, deep-throat clamps.
- Do not use any clamps that have a bent frame or a bent spindle.
- Do not use wrenches, pipes, hammers, or pliers to tighten clamps. Use wrenches only on clamps especially designed for wrenches.
- Do not hoist or pull with C-clamps. Use special lifting clamps.
- Do not use C-clamps to construct scaffolds or platforms for workers.

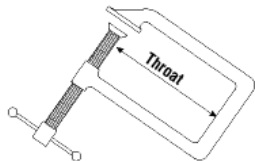

f. Basic Hand Tools

What are some basic tips when using hand tools?

- Always provide training on how to choose the right tool for the job, how to correctly use each tool, and how to identify when tools need repair.
- Select the right tool for the job. Substitutes increase the chance of having an accident.
- Use tools designed to allow wrist to stay straight. Avoid using hand tools with your wrist bent.
- Ensure that employees are properly trained in the safe use of hand tools.
- Use good quality tools.
- Keep tools in good condition at all times.
- Inspect tools for defects before use. Replace or repair defective tools.
- Keep cutting tools sharp and cover sharp edges with suitable covering to protect the tool and to prevent injuries from unintended contact.
- Replace cracked, splintered, or broken handles on files, hammers, screwdrivers, or sledges.
- Ensure that the handles of tools like hammers and axes fit tightly into the head of the tool.
- Replace worn jaws on wrenches, pipe tools and pliers.
- Redress burred or mushroomed heads of striking tools.
- Pull on a wrench or pliers. Never push unless you hold the tool with your palm open.
- Point sharp tools (e.g., saws, chisels, knives) lying on benches away from aisles and handles should not extend over the edge of the bench top.
- Maintain tools carefully. Keep them clean and dry, and store them properly after each use.
- Carry tools in a sturdy tool box to and from the worksite.
- Wear safety glasses or goggles, or a face shield (with safety glasses or goggles) and well-fitting gloves appropriate for the hazards to which you may be exposed when doing various tasks.
- Keep the work environment clean and tidy to avoid clutter which may cause accidents.
- Use a heavy belt or apron and hang tools at your sides, not behind your back.



What should I avoid when using hand tools?

- Do not use tools for jobs they are not intended to do. For example, do not use a slot screw drivers as a chisel, pry bar, wedge or punch or wrenches as hammers.
- Do not apply excessive force or pressure on tools.
- Do not cut towards yourself when using cutting tools.
- Do not hold the stock in the palm of your hand when using a cutting tool or a screwdriver.
- Do not wear bulky gloves to operate hand tools.
- Do not throw tools. Hand them, handle first, directly to other workers.
- Do not carry tools in a way that interferes with using both hands on a ladder, while climbing on a structure, or when doing any hazardous work. If working on a ladder or scaffold, tools should be raised and lowered using a bucket and hand line.
- Do not carry a sharp tool in your pocket.



g. Struck Tools

What are some safety tips to know when using a struck tool?

Struck tools are made in various shapes and sizes and for many uses and include cold chisels, punches, nail sets, rock and star drills, and wedges. Use the correct tool for the job.

- Wear safety glasses or goggles, or a face shield (with safety glasses or goggles).
- Use the tools only if they are good condition (i.e., cutting edges are sharp, struck head is not mushroomed or chipped).
- Hold the chisel, for shearing and chipping, at an angle which permits the bevel of cutting edge to lie flat against the shearing plane.

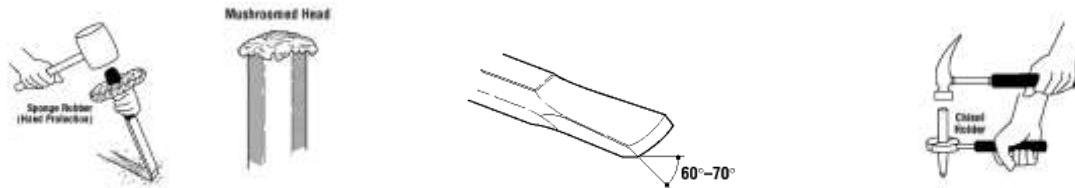

- Provide hand protection
- Hand protection can be provided by a sponge rubber shield forced onto the shaft of a chisel or select struck tools that come with hand protectors designed for the tool.
- Punch and chisel holders are also available.
- Discard tools which are bent, cracked or chipped.
- Redress striking tools with burred or mushroomed heads.
- Redress the point or cutting edge to its original shape. Grind to a slightly convex cutting edge. The point angle of the chisel should be 70° for hard metals, 60° for soft.

What should I avoid doing?

- Do not use struck tools if the struck end is chipped or mushroomed.
- Do not use struck tools if the cutting edge is dull or chipped or if the point of a punch is slanted or damaged.
- Do not apply too much pressure to the head when grinding a chisel. The heat generated can remove the temper.
- Immerse the chisel in cold water periodically when grinding.
- Do not use cold chisels for cutting or splitting stone or concrete.
- Do not use a drift pin punch (also called an aligning punch) as a pin punch intended for driving, removing, or loosening pins, keys, and rivets.
- Do not allow bull point chisels to be hand-held by one employee and struck by another. Use tongs or a chisel holder to guide the chisel so that the holder's hand will not be injured.

h. Pliers and Wire Cutters

What are common types of pliers and wire cutters?

Pliers are made in various shapes and sizes and for many uses. Some are used for gripping something round like a pipe or rod, some are used for twisting wires, and others are designed to be used for a combination of tasks including cutting wire. There are also tools that are used just for cutting wires (as opposed to wire cable and rope). Use the correct pliers or wire cutters for the job.

Proper use of **side cutting (lineman's) pliers**:

- Many applications including electrical, communications and construction work
- Use to grip, splice or cut wires, and strip insulation.



Side Cutting (Lineman's) Pliers

Proper use of **long nose pliers**:

- Use to grip small objects, reach awkward places, holding wires, bend loops, and attach wires
- Work involving smaller gauge wire.



Long Nose Pliers

Proper use of **utility pliers**:

- Use to grip round square, flat and hexagonal objects.
- Can apply limited torque (twisting force) without damaging the work.

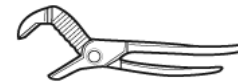

Utility Pliers

Proper use of **diagonal cutting pliers**:

- For work involving cutting and skinning wires, cutting and removing pins, nails and other fasteners.

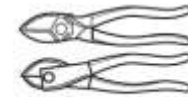

Diagonal Cutting Pliers

Proper use of **flat nose pliers**:

- Common pliers, used in many applications and assembly work.
- Use to grip, turn and bend wires.



Flat Nose Pliers

Proper use of **slip joint pliers**:

- Used to adjust nuts or bolts.



Slip Joint Pliers

Proper use of **end cutting pliers**

- Use for cutting wires, nails, rivets close to work.



End Cutting Pliers

What are some safety tips to know when using pliers and wire cutters?

- Wear safety glasses or goggles, or a face shield (with safety glasses or goggles) whenever there is a potential hazard from flying particles, pieces of wire, etc.
- Cut at right angles. Never rock the cutting tool from side to side or bend wire back and forth against the cutting edges.



- Choose pliers or wire cutters that have a grip span of 6 cm - 9 cm (2 1/2 - 3 1/2 in.) to prevent your palm or fingers from being pinched when the tools are closed.
- Use adjustable pliers that allow you to grip the work piece firmly while maintaining a comfortable handgrip (i.e., hand grasp is not too wide).
- Use tools only if they are in good condition.
- Make sure that the cutting edges are sharp. Dull and worn down cutting edges require many times more force needed for cutting.
- Make sure that the toothed jaws are clean and sharp. Greasy or worn down jaws can result in compromised safety. Such tools also require increased force to hold the workpiece which, in turn, increases the risk of muscular fatigue and repetitive strain injuries.
- Oil pliers and wire cutters regularly. A drop of oil on the hinge will make the tools easier to use.
- Pull on the pliers; do not push away from you when applying pressure. If the tools slips unexpectedly, you may lose your balance or hit your hand against equipment or something else hard that could result in an injury.

What should I avoid doing?

- Do not cut hardened wire unless the pliers or wire cutters are specifically manufactured for this purpose.
- Do not expose pliers or wire cutters to excessive heat.
- Do not bend stiff wire with light pliers. Needle nose pliers can be damaged by using the tips to bend large wire. Use a sturdier tool.
- Do not use pliers as a hammer.
- Do not hammer on pliers or wire cutters to cut wires or bolts.
- Do not extend the length of handles to gain greater leverage. Use a larger pair of pliers for gripping or a bolt cutter for cutting.
- Do not use cushion grip handles for jobs requiring tools with electrically insulated handles. Cushion grips are for comfort primarily and do not protect against electric shock.
- Do not use pliers on nuts and bolts; use a wrench.

i. Push Sticks

When should you use push sticks?

Push sticks or push blocks should be used when operating standard woodworking machinery, including table saws, band saws, radial arm saws, jointer/planers and shapers. These sticks protect the hand while allowing good hand control of the stock as it is pushed through the cutting head or blade. Push blocks for Jointer/Planers should be constructed for two-handed positioning.

- Always use a push stick for pieces less than 30 cm (1 ft) in length, or for the last 30 cm of a longer cut.
- Use the push stick to remove the cut piece from between the fence and the blade.

What are some features of a push block?

Hold-down push blocks should:

- be rigid
- enable the operator to protect both hands
- allow the operator to exert a firm and steady pressure on the work piece.

The following are samples of push blocks.

- Simple push sticks are useful on a table saw when distance between the blade and fence is narrow.
- ✓ Double-handed hold-down push block
- Frontal Push Block
- Side Push Block
- Use of two push blocks on single application

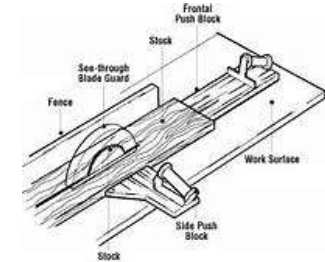
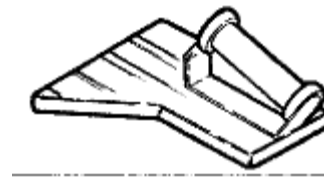
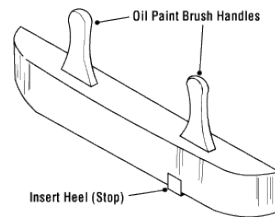
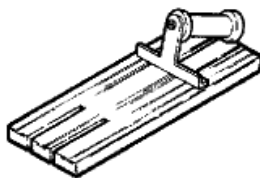
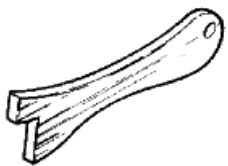

j. Non Sparking Tools

What is a "non-sparking" tool?

"Non-sparking", "spark reduced", "spark-resistant" or "spark-proof" tools are names given to tools made of metals such as brass, bronze, Monel metal (copper-nickel alloy), copper-aluminium alloys (aluminium bronze), or copper-beryllium alloys (beryllium bronze). Commonly used hand tools are often manufactured of steel alloys. Preferred "non-sparking" metals have less tensile strength than steels usually used to make tools. A lower tensile strength means the metal has less strength or resistance to tearing apart when stretched under test conditions. It also means that these tools are softer, wear down more quickly than ordinary steel tools, and have to be dressed more frequently.

What is the most important thing to know about "non-sparking" tools?

Non-sparking tools also generate sparks sometimes referred to as "cold sparks". These cold sparks have a low heat level and do not ignite carbon disulphide, which has the lowest ignition point of any substance known to man. Therefore while "non-sparking" tools may lower the risk of a spark, they do not eliminate the possibility of sparks. The name "non-sparking" is misleading because these tools are capable of producing a spark: the term "reduced-sparking tools" better describes these tools.

Non-metals like wood, leather, and plastic are suitable for some tools like shovels, scrapers or scoops and do not pose a friction spark hazard.

Non-sparking tools provide protection against fires and explosions in environments where there is a concern about sparks igniting flammable solvents, vapours, liquids, dusts or residues. There are many standards and recommendations that have been published by OSHA (Occupational Health and Safety Administration) and NFPA (National Fire Protection Association) that advise the use of non-sparking tools in hazardous environments.

NOTE: It is important to assess each situation carefully and use the appropriate tools for the hazards that are present. In some cases, "non-sparking" tools may still be able to produce a spark. Contact the tool manufacturer, and the producer of the flammable material (for example) for recommendations and more information.

What are the hazards of both "sparking" and "non-sparking" tools?

Both "sparking" and "non-sparking" materials can cause ignition. Two types of hazards are associated with tools manufactured of either material:

1. Ignition by friction, with impact on each other or on other materials such as steel or concrete, in which an "ordinary" (mechanical or frictional) spark is generated. All tools can ignite flammable mixtures by sparks generated by friction or impact. However, this is true only when the generated spark is incendive: that means a spark that has to have enough heat content (i.e., enough mass and sufficiently high temperature) and has to last long enough to heat a flammable air-vapour mixture above its ignition temperature. This is more likely in the case of sparks formed when using a metal grinder than a spark generated when a hammer strikes some metal.
2. Ignition by a chemically-generated spark, caused by impact between certain metals and some oxygen-containing substances (such as rust, which is iron oxide).

How should you use and maintain "non-sparking" tools?

Follow the guidelines below to reduce the risk of explosion and fire.

- Make sure all "non-sparking" tools are kept clean and free from ferrous or other contaminants, which may hamper the non-sparking properties.
- Do not use non-sparking hand tools in direct contact with acetylene, which may form explosive acetylides, especially in the presence of moisture.
- Use local or mechanical ventilation systems as appropriate to remove hazardous materials, dusts and vapours from the workplace.
- Follow normal safety procedures when sharpening non-sparking tools such as the provision of eye and face protection, adequate extraction and dust collection facilities.

What is the best safeguard against accidental explosions?

Follow safe work procedures. Always evaluate a job to be done in a hazardous environment (even the simplest one)! Use proper tools and equipment that eliminate ignition such as electric motors that can be certified as "explosion proof" for use in most hazardous work locations or non-sparking tools with proper use and maintenance.

Keep in mind that there are no truly non-sparking tools. In any work where flames are used, or sparks are produced, make sure that an explosive atmosphere does not develop. Such atmospheres include flammable vapour-air mixtures and organic dust clouds like flour or coal dust.

Isolation, ventilation and purging are methods of insuring a safe working atmosphere.

k. Hand Saws

What should I know about hand saws?

Saws are made in various shapes and sizes and for many uses. Use the correct saw for the job.

- Wear safety glasses or goggles, or a face shield (with safety glasses or goggles).
- Select a saw of proper shape and size for stock being used.
- Select a saw with the number of teeth per inch (TPI) in order to get the desired finish. For example: a coarse tooth blade (e.g., 2 or 3 TPI) should be used for thicker stock. 18 to 32 TPI should be used on thinner metals or plastic (0.5 cm or 1/4 inch). General wood cutting typically requires about 4 TPI.
- Choose a saw handle that keeps wrist in a natural position in the horizontal plane.
- Choose saw with a handle opening of at least 12 cm (5 in.) long and 6 cm (2.5 in.) wide and slanted at a 15° angle.

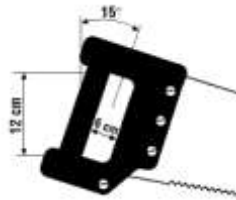

- Check the stock being cut for nails, knots, and other objects that may damage or buckle saw.
- Start the cut by placing your hand beside the cut mark with your thumb upright and pressing against blade. Start cut carefully and slowly to prevent blade from jumping. Pull upward until blade bites. Start with partial cut, then set saw at proper angle.
- Apply pressure on downstroke only.

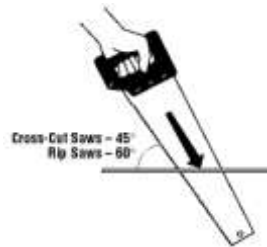

- Hold stock being cut firmly in place.
- Use a helper, a supporting bench or vice to support long stock if required.
- Keep teeth and blades properly set.
- Protect teeth of saw when not in use.
- Keep saw blades clean.

What should I know about using a hacksaw?

- Select correct blade for material being cut.
- Secure blade with the teeth pointing forward. Tighten the nut until the blade is under tension.
- Keep blade rigid, and frame properly aligned.
- Cut using steady strokes, directed away from you.

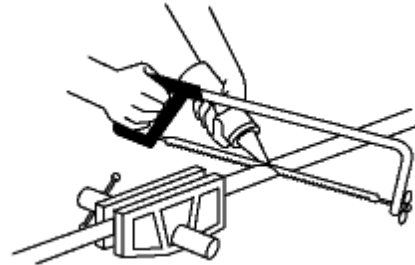

- Use entire length of blade in each cutting stroke.
- Use light machine oil on the blade to keep it from overheating and breaking.
- Cut harder materials more slowly than soft materials.
- Clamp thin, flat pieces requiring edge cutting.
- Keep saw blades clean and lightly oiled.
- Do not apply too much pressure on the blade as the blade may break.
- Do not twist when applying pressure.
- Do not use when the blade becomes loose in the frame

1. Snips

What are some safety tips to know when using snips?

Snips are made in various shapes and sizes for various tasks. The handle can be like those on scissors with finger and thumb holes or like plier handles. Models are available for cutting in straight lines, in curves to the left or curves to the right.

- Universal snips can cut in both straight and wide curves.
- Straight snips and duckbill snips (flat blade, "perpendicular" to the handle, with pointed tips) are designed to cut in straight lines; some duckbill snips are designed for cutting curved lines.
- Hawk's bill snips (with crescent-shaped jaws) are used for cutting tight circles.
- Aviation snips have compound leverage that reduces the effort required for cutting.
- Offset snips have jaws that are set at an angle from the handle.

DO

- Select the right size and type of snips for the job; check manufacturer's specifications about the intended use of the snips (e.g., type of cut - straight, wide curve, tight curve, right or left, and maximum thickness and kind of metal or other material that can be cut).
- Only use snips that are sharp and in good condition.
- Wear safety glasses or goggles, or a face shield (with safety glasses or goggles) and protective gloves when working with snips. Small pieces of metal may go flying in the air and the cut edges of metal are sharp.

Left cut snips are for making cuts to the left and straight cuts.

Right cut snips are for making straight cuts and cuts to the right.

Straight cut snips (not shown) are for making straight cuts and shallow cuts to the right or left.

Offset snips permit you to keep your hands safely above the cut while cutting directly through the centre of a large sheet.

- Use snips for cutting soft metal only. Hard or hardened metal should be cut with cutting tools designed for that purpose.
- Use ordinary hand pressure for cutting. If extra force is needed, use a larger tool.
- Cut so that the waste is on the right if you are right-handed or on the left if you are left-handed.
- Avoid springing the blades. This results from trying to cut metal that is too thick or heavy for the snips you are using.
- Keep the nut and the pivot bolt properly adjusted at all times.
- Oil the pivot bolt on the snips occasionally.

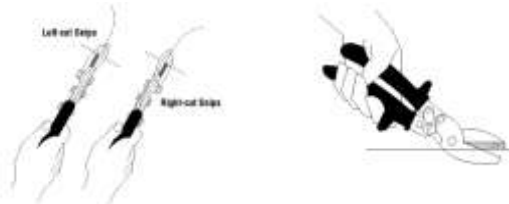

- Use the locking clip (if available) to keep the snips closed when not in use.

What should I avoid doing?

- Do not try to cut sharp curves with straight cut snips.
- Do not cut sheet metal thicker than the manufacturer's recommended upper limit (e.g., cuts up to 16 gauge cold rolled steel or 18 gauge stainless steel).
- Do not extend the length of handles to gain greater leverage.
- Do not hammer or use your foot to exert extra pressure on the cutting edges.
- Do not use cushion grip handles for tasks requiring insulated handles. They are for comfort primarily and not for protection against electric shocks.
- Do not attempt to resharpen snips in a sharpening device designed for scissors, garden tools or cutlery.

m. Cutting Tools for Bolts Cables and Strapping

What are some general safety tips to know when using cutting tools?

Many types and sizes of cutters are used for cutting selected metal products made from iron, steel, or softer, non-ferrous materials (e.g., copper, brass, aluminium). Cutters are designed to cut materials of different kinds of products such as wires, cables (electrical, coax, multi-strand), wire ropes, fencing, bolts, rods, pre-stressed concrete wires, and strapping.

- Wear safety glasses or goggles, or a face shield (with safety glasses or goggles) and protective gloves when using cutters.
- Choose the proper cutter for the job. Cutters are designed for a specific type, hardness, and size of material.
- Cut materials straight across - keep the material being cut at right angles to the cutting edges of jaws.
- Prevent injury from flying metal by wrapping a burlap bag, cloth or rag around the cutting jaws. Metal can fly when cut.
- Warn those in the area to take precautionary measures to avoid possible injury from flying metal pieces.
- Keep cutting tools in good repair.
- Adjust and lubricate cutter and moving parts daily if heavily used.
- Sharpen jaws according to manufacturers' instructions.



What should I avoid doing?

- Do not use a cutting tool until you are trained in its proper and safe use.
- Do not use cushion grip handles for jobs requiring insulated handles. Cushion grips are for comfort primarily and do not protect against electric shock.
- Do not use cutters which are cracked, broken or loose.
- Do not exceed the recommended capacity of a tool.
- Do not cut diagonally.
- Do not rock cutters from side to side when cutting wire.
- Do not pry or twist with tool when cutting.
- Do not hammer on cutting tools or extend the handle length to achieve greater cutting power.
- Do not expose cutters to excessive heat.
- Do not repair cutters. Discard equipment that is cracked, broken or shows signs of damage.

Appendices 1 Grievance Policy & Procedures

AMSA highly recommends that all Men's Sheds have in place a Grievance Policy. It is recognised that sponsored Men's Sheds may have a Grievance Policy which they are required to follow – it is not intended that this Policy replace the sponsor body Policy.

This policy defines Men's Shed related grievances and describes how they are to be handled. It advises on:

- The responsibilities of members,
- How to raise a grievance,
- The expected outcomes of the process and
- Documentation.

Rationale

AMSA wishes to maintain a harmonious environment in Men's Sheds that is free from intimidation and harassment and which affords equality of opportunity.

All Men's Sheds want members to express concern about Shed- related issues and to raise concerns with other members on an informal basis, in the first instance, and, if not resolved, to seek recourse to more formal grievance and dispute procedures.

AMSA is committed to fair grievance handling. The grievance handling process will be conducted in a way that ensures procedural fairness is upheld, confidentiality is maintained, and that steps are taken to eliminate victimisation.

What is Grievance?

A Men's Shed related grievance is any type of problem, concern or complaint where a member believes that he/she has received unreasonable treatment from the Men's Shed, or from another member and wishes to bring the grievance to the attention of the Men's Shed Committee or authorised person and requires an action or response.

Principles

Confidentiality:

Only the people directly involved in making or investigating a matter will have access to information about the matter

Impartiality:

All parties involved will have the opportunity to provide details regarding the matter. No assumptions will be made and no action will be taken until all relevant information has been collected and assessed. Complainants using this process are protected from any detrimental action, including victimisation.

Timeliness:

All matters will be dealt with in a timely manner. All relevant parties will be kept informed of developments. An informal meeting will be held between the member/s and the Manager to discuss the grievance or dispute and the remedy sought. If the grievance cannot be resolved informally, the matter will progress to the formal stage and be resolved in a timely manner

Fairness:

This policy endeavours to provide procedures by which aggrieved persons may receive prompt, fair and consistent consideration of complaints.

Who is accountable for handling grievances?

Men's Shed Committees or authorised persons are responsible for responding appropriately to grievances and managing the process according to the AMSA policies, principles and procedures.

Members Reporting a Grievance (Stage 1)

A member who has a problem or concern with a team member is encouraged to initially attempt to discuss and resolve the issue directly with the team member who is the subject of the concern. Inform the team member directly that they are acting in an inappropriate way and that their behaviour is unacceptable to the complainant. An opportunity is provided for them to stop and change behaviour before the matter becomes a formal grievance.

The Shed Committee or authorised person's Initial Response to a Report of a Grievance (Stage 2)

The Committee will, if possible, attempt immediate resolution. If the grievance is resolved in this manner, the Committee will document the actions taken and advise the complainant of the outcome.

Acknowledgement/Further Assessment of Grievance (Stage 3)

If an immediate resolution was not possible or achieved, the Shed Committee or authorised person will ask the complainant to put the grievance in writing and the Committee or authorised person will undertake a further assessment of the grievance and the Committee or authorised person will advise the complainant of the grievance resolution procedure.

Notification to Respondent (Stage 4)

The Committee or authorised person will inform the respondent in writing that a grievance complaint has been made against them and provide them with a copy of the grievance complaint. The Respondent will also be advised of the grievance resolution procedure.

Respondents will be advised by the Committee or authorised person that they will be given every opportunity to respond to the allegations.

The Committee or authorised person will advise the respondent that they will be informed regularly of progress towards resolution, and that they must observe the principle of confidentiality. The respondent must not contact the complainant about the grievance during the resolution process.

Investigation of Grievance and Interview Preparation

The Committee or authorised person will undertake an investigation of the grievance, which may include interviews, a review of relevant documentation and an inspection of the workplace, and any other actions, which will assist in determining what further action is required.

The Committee or authorised person will review all additional and specific details requested from, and provided by, the complainant, and advise the respondent in writing of each specific allegation that has been made, seeking a written response to each allegation.

As much detail as possible should be given to the respondent who will be given an appropriate period of time to respond to the allegation/s

The Committee or authorised person will provide interviewees with at least 24 hours notice prior to the interview and will advise them of the nature and purpose of the interview.

Interviews

- ✚ If interviews are required, the complainant and the respondent will be interviewed separately, and each given the opportunity to present their respective cases.
- ✚ Each party may have a support person present during their interview; however support persons take no active role in the interview.
- ✚ The interviews will be held in privacy and conducted impartially
- ✚ During the interview process, each specific allegation will be put to the respondent to allow them to respond and provide his/her version of events, and comment on any relevant issue.
- ✚ Records of each interview will be taken and each interviewee provided with a copy of the record of interview as soon as possible after the interview.
- ✚ In some matters it may be necessary for interviews to be recorded. This will only occur with the interviewee's knowledge and permission. The interviewee will be provided with a copy of the unedited recording of the interview.

Outcome of Investigation

At the conclusion of the investigation the Committee or authorised person will prepare a report determining whether the grievance was substantiated, outlining the supporting evidence for the conclusion.

The Committee or authorised person will decide what action will be taken and it will be determined whether:

The matter is substantiated (it happened)

The following actions may be required from the person who caused the grievance and which will be appropriate to the behaviour complained about:

1. A written apology
2. An official warning
3. Counselling

The matter is not substantiated (there is not enough proof)

The following actions may be required:

1. Counselling and additional training for staff
2. Monitoring the member's behaviour

The matter was frivolous, vexatious or contrived (i.e. it did not happen)

The following actions may be required:

1. Counselling for the person who made the grievance
2. An official warning

The person lodging the grievance will be advised of all outcomes as will any other relevant party. If the matter remains unresolved the Committee or authorised person should provide the member/s with a written response. The response should include the reasons for not implementing any proposed remedy.

Monitoring the Outcome

The Committee or authorised person will monitor the outcome of the grievance resolution process. If the grievance was substantiated, monitoring will occur to ensure the solution is working satisfactorily. If not, the Manager will take appropriate corrective action.

Appeals (Stage 5)

If a member wishes to appeal with regard to the process and the outcome of the grievance resolution, they should do so in writing to the AMSA.

Appendices 2 New Shed Typical Start up Equipment & Tool List

Fire Safety Equipment

- ✚ Fire equipment such as extinguishers
- ✚ Fire Evacuation Plan and wall illustration
- ✚ Fire blanket

First Aid Kit

If purchased, the First Aid Kit will include all relevant equipment. Alternatively the Men's Shed can develop its own-the list of items below is a good start however other items may be added depending upon the range of activities undertaken. It is important that a regular check of First Aid Kits is undertaken and items replenished as needed.

In addition to the Kit, a plentiful supply of eye wash and hand wash is recommended.

Personal Safety Equipment

- ✚ Eye protection goggles/glasses
- ✚ Ear muffs and Ear plugs
- ✚ Dust masks (ordinary)
- ✚ Specialist dust masks - with breathing cones
- ✚ Vinyl/rubber gloves
- ✚ Riggers Gloves (to protect against splinters etc)
- ✚ Safety Notices for machines and handling

Chemical Storage Cupboard

Steel cupboard approved for storage of dangerous chemicals -such as Mentholated Spirits, turps, varnishes, linseed oil, paint strippers. ***Please Note:** Obtaining all SDS forms for chemicals from the supplier at point of sale will save a lot of time later.

Bench/Floor Tools

- ❖ Circular Saw Bench
- ❖ Band Saw
- ❖ Drop Saw or Compound Saw
- ❖ Jig Saw (or Sabre Saw)
- ❖ Pedestal Drill (a small one is quite sufficient)
- ❖ Belt and Disc Sander
- ❖ Router and stand
- ❖ Lathe
- ❖ Thicknesser & Jointer Planer

Hand Tools

- ❖ Cordless Drills (at least 2)
- ❖ Miscellaneous Clamps
- ❖ Hammers
- ❖ Handsaws
- ❖ Planes
- ❖ Screwdrivers
- ❖ Orbital and mouse Sander

Miscellaneous materials

- ❖ Wood & Plywood- of various lengths and thicknesses. Much of our wood is recycled wood from tips, council cleanups and wood donations from local residents
- ❖ Wide variety of sizes of screws, nails, nuts and bolts (and appropriate containers)
- ❖ Variety of hinges, clasps
- ❖ Extra drill bits
- ❖ Some plans/specifications for toys and projects.

Others

- ❖ Wet area for cleaning of paint brushes etc
- ❖ Kitchenette area for coffee/tea preparations
- ❖ 2-3 Work benches
- ❖ Storage areas/boxes for hand tools
- ❖ Storage racks for timber / metal and other materials
- ❖ A 'secure cage' to store portable power tools and other attractive items.



Appendices 3 RISK ASSESSMENT SHEET

Location:	
Name of person conducting assessment:	
Date:	

Spot the Hazard		Assess the Risk	Fix the Problem			Evaluate Results
Identify the work task or activity	What are the risks with each activity?	Is the associated risk low, moderate, significant or high?	If the risk is unacceptable for the task, what will be done to reduce or remove the risk?	By whom?	By when?	Repeat assessment. Are Risk levels now acceptable?
						Revised risk level

Appendices 3a RISK ANALYSIS THINKING PROMPTS

<p>Physical</p> <ul style="list-style-type: none"> • Noise • Vibration • Radiation • Unguarded equipment • Machinery/plant • Apparatus • Storage • Traffic • Electrical • Lighting • Heat • Air • Cold • Wet • Damp • Flow • Dust • Tripping • Cutting • Crushing • Height • Falling • Clutter • Sharp Edges <p><u>Work Environment</u></p> <ul style="list-style-type: none"> • Security • Access/Egress • Perimeter • Evacuation • Emergencies • Space 	<p>Ergonomic</p> <ul style="list-style-type: none"> • Workplace design/layout • Manual handling and lifting • Repetitive actions • Use of tools/equipment <p>Biological</p> <ul style="list-style-type: none"> • Bacterial • Viruses (HIV, Hepatitis) • Fungus • Insect/Snake bites • Organic dusts (wheat) • Allergies <p>Chemical</p> <ul style="list-style-type: none"> • Vapours • Fumes • Flammability • Explosive • Direct contact • Oxygen • Toxic • Corrosive • Powder • Containment <p>Buildings</p> <ul style="list-style-type: none"> • Brickwork • Roof • Timber Structures • Gutters • Glass • Fencing • Uneven Ground • Taps and Toilets
--	--



Appendices 4. SAFETY DATA SHEET

Example: All Purpose Detergent page 1

Safety Data Sheet



Hazardous Chemical, NON-Dangerous Goods

1. MATERIAL AND SUPPLY COMPANY IDENTIFICATION

Product name: All Purpose Detergent

Synonyms

ALL PURPOSE DETERGENT 15L
ALL PURPOSE DETERGENT 25L
ALL PURPOSE DETERGENT 5L

Bar Code

9326157002959
9326157002966
9326157002973

Recommended use: Hospital Grade Detergent

Supplier: Peerless JAL Pty Ltd
ABN: 53 006 489 345
Street Address: 6-12 Raglan Street
Preston 3072
Australia
Telephone: +613 9416-6700
Facsimile: +613 9416 8516

Emergency Telephone number: 03 9416-6700

2. HAZARDS IDENTIFICATION

This material is hazardous according to health criteria of Safe Work Australia.



Signal Word

Warning

Hazard Classifications

Skin Corrosion/Irritation - Category 2
Serious Eye Damage/Irritation - Category 2A

Hazard Statements

H315 Causes skin irritation.
H319 Causes serious eye irritation.

Prevention Precautionary Statements

P102 Keep out of reach of children.
P103 Read label before use.
P264 Wash hands, face and all exposed skin thoroughly after handling.
P280 Wear protective clothing, gloves and eye/face protection.

Response Precautionary Statements

P101 If medical advice is needed, have product container or label at hand.
P302+P352 IF ON SKIN: Wash with plenty of soap and water.
P305+P351+P338 IF IN EYES: Rinse cautiously with water for several minutes. Remove contact lenses, if present and easy to do. Continue rinsing.
P332+P313 If skin irritation occurs: Get medical advice/attention.
P337+P313 If eye irritation persists: Get medical advice/attention.

Appendices 5

AMSA Recommended Men's Shed Health & Safety Audit Quarterly Checklist

GENERAL ITEMS	<i>Please tick one</i>	
	YES	NO
1. Are the owned premises you occupy and major equipment insured (contact AMSA for insurance options)		
2. Have you or do you intend to lease premises or equipment?		
3. Are the entrances and emergency exits clearly marked?		
4. Do you regularly practice (at least every six months) fire drills / emergency evacuation?		
5. Are there procedures for dealing with fire/bomb threat / explosion/flood?		
6. Are members trained in the above procedures?		
7. Do you have a Men's Shed Health & Safety manual that is out of date?		
8. If a member or organisation hires a room / centre, do you check on the hirer's Public Liability Insurance?		
9. Has your Men's Shed been required to sign any form of indemnity in relation to the delivery of its services, hire of property or equipment, use of contractors, etc.?		
EQUIPMENT		
10. Have operators of equipment been trained in their use?		
11. Do you consider human differences in height, strength, allergies, etc. when allocating work tasks?		
12. Is personal protective equipment (PPE) always used by members in instructions/policies e.g. gloves, safety glasses, aprons, helmets?		
13. Are hand tools such as knives, cooking tools, brushes, mops, hammers, saws, etc. kept in good order and replaced if they become faulty?		
14. Are hand tools such as knives, cooking tools, brushes, mops, hammers, saws, etc. checked monthly to ensure they are in good order?		
15. Are transport / special vehicles suited to the task and in a sound condition?		
16. Are ladders / steps used by volunteers – are they safe and sturdy and suited to the job?		
PEOPLE ISSUES		
17. Are members exposed to noise levels that interfere with normal speech level conversation?		
18. Is it possible that anyone working will be unable to hear alarms because of a disability or noise levels?		
19. Is noise protection equipment needed and available?		
20. For members whose disability is general knowledge, is adequate care taken to assist them? In instances where disabilities are held private – is privacy respected?		
21. Are enough members available to ensure transportation and outings are conducted with safety?		
22. Is anyone subject to substantial vibrations from the work they do for periods longer than 5 minutes? - full body vibration? - hand / arm vibrating?		
23. Is anyone exposed to excessive radiation from the sun, welding, x-ray? Do they wear protective equipment?		
24. Is lighting adequate to perform tasks safely?		
25. Is any medication administered to members on a routine basis? (prescription or non prescription)		

APPENDICES 6 SAFETY SIGNAGE

Each Men's Shed will require some common signage such as:

- ✚ Exit Signs
- ✚ Footwear Protection
- ✚ Eye Protection
- ✚ Noise Protection
- ✚ Various Danger Signs

There are hundreds of signs to choose from and they have by and large been already designed to meet legal requirements.

Before trying to design your own signs, an Internet search will provide you with literally hundreds of websites that offer Workplace Health & Safety signage at a reasonable price.

Example

<http://www.australiansafety signs.com>

AMSA has downloaded a sample of signs that can be printed and laminated with plastic before being displayed in the Shed.

A visit to your nearest hardware store can also provide you with other signs to meet your Shed's requirements.



